

RECORDER  
VANDERBURGH COUNTY  
DEBBIE STUCKI  
2024R00008628  
05/15/2024 02:14 PM  
RECORDING FEES: 25.00  
PAGES: 86

**DECLARATION OF CONDOMINIUM OWNERSHIP**

**OF**

**BRIAR POINTE ESTATES CONDOMINIUMS**

**A HORIZONTAL PROPERTY REGIME**

*REFERENCE AFFIDAVIT in Aid of TITLE  
2024 R0000 8627*



DECLARATION OF CONDOMINIUM OWNERSHIP  
FOR  
BRIAR POINTE ESTATES CONDOMINIUMS

RECITALS

1.	Definitions.....	5
2.	Declaration of Condominium .....	8
3.	Description of Buildings .....	8
4.	Legal Description of Land .....	8
5.	Description of Condominium Units.....	9
	a. Description of Units .....	9
	b. Appurtenances.....	9
	c. Boundaries.....	10
6.	Common Areas and Facilities.....	10
7.	Limited Common Areas and Facilities .....	11
8.	Ownership of Common Areas and Percentage Interest .....	12
9.	Encroachments and Easements for Common Areas .....	12
10.	Casualty and Restorations.....	12
	a. Partial Destruction.....	13
	b. Complete Destruction .....	13
	c. Determination of Complete Destruction .....	13
	d. Exception in Limited Common Areas .....	13
11.	Association of Co-Owners.....	13
12.	Declarant's Use of Condominium Unites.....	14

13	<b>Maintenance, Decoration, Repairs and Replacements</b> .....	14
	a. <b>Common Areas</b> .....	14
	b. <b>Units</b> .....	15
14.	<b>Alterations, Additions and Improvements</b> .....	15
15.	<b>Amendment of Declaration</b> .....	16
	a. <b>Notice</b> .....	16
	b. <b>Resolution</b> .....	16
	c. <b>Meeting</b> .....	16
	d. <b>Adoption</b> .....	16
	e. <b>Restrictions upon Amendments</b> .....	16
	f. <b>Recording</b> .....	18
	g. <b>Amendments by Declarant Only</b> .....	18
	h. <b>Amendment Prior to Applicable Date</b> .....	18
16.	<b>Acceptance and Ratification</b> .....	18
17.	<b>Expandable Condominium and Declarant’s Reserved Option No to Expand</b> .....	19
18.	<b>Contractable Condominium</b> .....	22
19.	<b>Granting and Amendment of Easements</b> .....	23
20.	<b>Reserved Rights, Streets, Facilities and Other Easements</b> .....	23
21.	<b>Initial Management</b> .....	24
22.	<b>Restrictions, Rules and Regulations</b> .....	25
	a. <b>Restrictions on Use</b> .....	25
	b. <b>Right of Board to Adopt Rules and Regulations</b> .....	30
	c. <b>Enforcement</b> .....	30

23.	Assessments and Limitation Upon Declarant's Liability for Assessments .....	30
24.	Sale or Lease of Condominium by Owner.....	30
	a. Lease .....	30
	b. Sale.....	31
	c. Statement of Regular or Special Assessments .....	31
25.	Right of Action .....	31
26.	Costs and Attorney's Fees .....	31
27.	Waiver.....	31
28.	Severability .....	31
29.	Rules of Interpretation .....	31
30.	Exculpation .....	31

**DECLARATION OF CONDOMINIUM OWNERSHIP**

**OF**

**BRIAR POINTE ESTATES CONDOMINIUMS**

**A HORIZONTAL PROPERTY REGIME**

THIS DECLARATION, made this 15<sup>th</sup> day of May 2024, by JOHN ELPERS CONTRACTING, INC., an Indiana corporation doing business as GEN 3 Contracting (the "Declarant"),

**RECITALS**

WHEREAS, the Declarant is the sole owner of that portion of the Real Estate more particularly described in Exhibit "A" attached hereto and made a part hereof, as Phase I land (herein referred to as "Phase I") which shall be the first phase of an expandable condominium as herein described; and

WHEREAS, the Declarant desires to reserve the right to expand the condominium into the real property located in Vanderburgh County, State of Indiana, described and set forth on Exhibit "B" attached hereto and made a part hereof (hereinafter referred to as the "Real Estate" or the "Development Land"); and

WHEREAS, the Declarant intends to locate certain buildings for residential purposes and other improvements on Phase I, and Declarant desires and intends to submit Phase I together with all buildings and improvements as may be constructed thereon and other permanent fixtures of whatsoever kind thereof, and all rights and privileges belonging to or in any way pertaining thereto, to the provisions of the Horizontal Property Law of the State of Indiana, and pursuant thereto to establish a Condominium so as to enable the Declarant and its successors in interest to own the same under that type of ownership commonly known as condominium ownership; and

WHEREAS, the Declarant is further desirous of establishing for its own benefit and for the mutual benefit of all future owners or occupants of said Condominium, or any part thereof, certain easements and rights in, over, and upon said real property, and certain mutually beneficial restrictions, reservations, and obligations with respect to the proper use, conduct and maintenance of the Property (as hereinafter defined); and

WHEREAS, the Declarant desires to implement the Horizontal Property Regime as an "expandable condominium" under the procedures and subject to the terms provided by Indiana Code 32-25-7-2 and 32-25-8-13, and to convert portions of the Real Estate, from time to time, into the condominium as provided by the Horizontal Property Law of the State of Indiana and to implement The Horizontal Property Regime as a "Contractable Condominium" under the

procedures and subject to the terms provided by Indiana Code Sections 32-25-7-3 and 32-25-8-14; and

WHEREAS, the General Plan of Development showing the area subject to the condominium and the areas into which expansion may be made is attached hereto and incorporated herein as set forth on Exhibit "C-1", and the Site Plan showing the proposed buildings on Phase I is attached hereto as set forth on Exhibit "C-2", provided, however, the Declarant reserves the right to relocate the proposed buildings and the Declarant reserves the right to develop less than all of the land described on Exhibit "B"; and

WHEREAS, the Declarant desires and intends that the several owners, mortgagees, occupants and other persons hereafter acquiring any interest in said Property shall at all times enjoy the benefits of, and shall hold their interest subject to the rights, easements, privileges, and restrictions hereinafter set forth, all of which are declared to be in furtherance of a plan to promote and protect the cooperative aspects of ownership and to facilitate the proper administration of the Property, and are established for the purpose of enhancing and protecting the value, desirability and attractiveness of the Property.

NOW, THEREFORE, the Declarant for itself and its grantees, successors and assigns, for the purposes herein set forth, declares as follows:

### **DECLARATION**

1. **Definitions.** The following terms, as used in this Declaration shall mean the following, unless the context required otherwise:

"Act" means the Horizontal Property Law of the State of Indiana, Indiana Code Section 32-25, et seq., as amended. The Act is incorporated herein by reference.

"Applicable Date" means the earliest of (a) ten (10) years from the date of the sale of the first Condominium Unit in Briar Pointe Estates Condominiums; (b) four (4) months after ninety-five percent (95%) of the Condominium Units that may be developed on the Real Estate have been conveyed to purchasers, (c) the date the Declarant files of record in the Office of the Recorder of Vanderburgh County, an instrument waiving and releasing its reserved rights as set forth in Paragraph 17 of this Declaration, to expand or further expand Briar Point Condominiums, or (d) such earlier date as Declarant shall determine.

"Association" means Briar Pointe Estates Condominium Owners Association Inc., an Indiana nonprofit Corporation, being the association of co-owners of Briar Pointe Estates Condominiums as more particularly described in Paragraph 11 hereof.

"Board of Directors" or "Board" means the governing body of the Association, being the initial Board of Directors referred to in the By-Laws or the subsequent Board of Directors elected by the Owners in accordance with the By-Laws.

**"Building"** means any structure located on a portion of the Real Estate in which one (1) or more Condominium Units are located which may be submitted and subjected to the Act by this Declaration, or by Supplemental Declaration(s) as herein provided. The initial and additional Buildings to be built shall be more particularly described and identified on Plans to be prepared and filed with the Office of the Recorder of Vanderburgh County and in Supplemental Declaration(s) to this Declaration.

**"By-Laws"** means the By-Laws of the Association providing for the administration and management of the Property, a true copy of which is attached to this Declaration and incorporated herein by reference as Exhibit "D".

**"Briar Pointe Estates Condominiums"** is the name by which the Real Estate, Condominium and Regime shall be known.

**"Briar Pointe Subdivision"** means all sections of a subdivision developed by Briar Pointe Development, LLC and/or its successors or assigns in the vicinity of the Real Estate.

**"Condominium Unit"** means the enclosed space of each one of the living units constituting Briar Pointe Estates Condominiums, designed as a residence, consisting of one or more rooms with a direct exit to a public or private street and the enclosed space of the attached garage, as more particularly described and identified on the Plans and in Paragraphs 3 and 5 of this Declaration and each additional living unit that may be submitted and subjected to the Act and this Declaration by Supplemental Declaration(s) as herein provided, together with the undivided interest in the common elements appertaining thereto and in the Common Areas and Limited Common Areas appertaining to each such unit.

**"Common Areas"** means the common areas and facilities of Briar Pointe Estates Condominiums as identified in Paragraph 6 of this Declaration.

**"Common Expenses"** means expenses of administration of the Association and expenses for the administration, maintenance, repair and replacement of the Common Areas and facilities and Limited Common Areas and of shared facilities (to the extent provided herein) and all sums lawfully assessed against the Co-Owners by the Association as common expenses or as declared by the Act, this Declaration or the By-Laws.

**"Contractable Condominium"** means a condominium from which one (1) or more portions of the condominium Real Estate may be withdrawn.

**"Declarant"** means John J. Elpers Contracting, Inc., an Indiana corporation, and any its successors and assigns which it designates in one or more written recorded instruments to have the rights of Declarant hereunder, including, but not limited to, any mortgagee acquiring title to any portion of the Property pursuant to the exercise of rights under, or by foreclosure of, a mortgage executed by Declarant.

**"Declaration"** means this Declaration of Condominium Ownership of Briar Pointe Estates Condominiums as it may be lawfully amended and supplemented from time to time.

**"Expandable Condominium"** means a condominium to which real estate may be added.

**"Limited Common Areas"** means the limited common areas and facilities identified in Paragraph 7 of this Declaration.

**"Majority of Mortgagees"** means those Mortgagees who hold first mortgages on Condominium Units to which are allocated at least fifty-one percent (51%) of the Percentage Vote allocated to Mortgaged Units.

**"Majority of Owners", "Majority Vote", and "Majority of the Percentage Vote"** means the Co-Owners entitled to cast at least fifty-one percent (51%) of the Percentage Vote in accordance with the applicable percentages set forth in this Declaration and the Supplements thereto. In connection with a vote of the Co-Owners at a meeting, these terms shall mean at least fifty-one percent (51%) of the Percentage Vote present at the meeting.

**"Mortgaged Unit"** means a Condominium Unit that is subject to the lien of a mortgage held, insured or guaranteed by a Mortgagee.

**"Mortgagee"** means the holder, insurer or guarantor of a first mortgage lien on a Condominium Unit who has requested notice in accordance with the provisions of Section 10.01 of the By-Laws,

**"Owner" or "Co-Owner"** means a Person who or which owns the fee simple title to a Condominium Unit and an undivided interest in the Common Areas and facilities.

**"Percentage Interest"** means the percentage of undivided interest in the fee simple title to the Common Areas and Limited Common Areas appertaining to each Condominium Unit as specifically expressed in Paragraph 8 of this Declaration.

**"Percentage Vote"** means that percentage of the total vote accruing to all the Condominium Units which is appurtenant to each particular Condominium Unit and accrues to the Owner thereof.

**"Person"** means an individual, firm, corporation, partnership, association, trust, limited liability company, or other legal entity, or any combination thereof.

**"Phase"** means such portions of the Real Estate that shall be identified as Phase I, Phase II, and continuing successively, as have, as of any given time, been sequentially subjected to the Act by this Declaration or by a Supplemental Declaration with filing of the Plans thereof as herein provided.

**"Plans"** means the general development plan (which depicts the Real Estate that Declarant intends to subject to the Act and the areas into which expansion of the condominium development may be made), and the floor plans (showing the layout, elevation, location, unit numbers and dimensions of the initial and subsequent Buildings and Condominium Units), that



shall be prepared and certified by a registered architect or licensed professional engineer who shall certify that such Plans are accurate copies of portions of the plans of the building(s) as filed with and approved by the municipal or other governmental subdivision having jurisdiction over the issuance of permits for the construction of the building(s). Such plans may be supplemented and amended to reflect the addition of Buildings and Condominium Units as contemplated by Paragraph 17.

"Property" means the Real Estate and appurtenant easements, the Units, the Buildings, and all other improvements of every kind and nature whatsoever, now or hereafter located upon the Real Estate, and used in connection with the operation, use and enjoyment of the Condominium.

"Regime" means Briar Pointe Estates Condominiums, a horizontal property regime created by this Declaration pursuant to the Act.

"Restoration" means construction, reconstruction, building, or rebuilding of the Buildings, the Condominium Units, the Common Areas and the Limited Common Areas to not less than the same condition as they existed immediately prior to any loss, damage or destruction with the same type of architecture and using, where appropriate, new materials of like kind and quality.

"Super Majority" means those Owners eligible to cast not less than sixty-seven percent (67%) in the aggregate of the Percentage Vote eligible to be cast by the Owners.

"Supplemental Declaration" means any supplement or amendment to this Declaration that may be recorded by the Declarant and that imposes and extends the provisions of this Declaration to any part of the Real Estate and contains such complementary or supplementary provisions for such part of the Real Estate as are required or permitted by the Act or this Declaration.

2. **Declaration of Condominium.** Declarant hereby expressly declares that the Real Estate as described herein on Exhibit "A" shall be a Horizontal Property Regime in accordance with the provisions of the Act.

3. **Description of Buildings.** The overall layout of Phase I of the Condominium is set forth on Exhibit "C-2". Phase One of the Condominium shall consist of Nine (9) Buildings containing not more than Sixteen (16) Condominium Units, without basements, but with attached garages, as shown on the Plans recorded at the time of recording this Declaration and attached hereto as Exhibits "C-3", "C-4", and "C-5". There may be up to Sixty-Eight (68) Units constructed on the Real Estate as part of the entire Condominium development, including areas into which the Condominium may be expanded.

4. **Legal Description.** Each Condominium Unit shall be identified on the Plans by a distinct letter which identifies the Condominium Unit. The legal description for each Condominium Unit shall consist of the number for such Condominium Unit as shown on the Plans and shall be stated as "Condominium Unit \_\_\_\_ (the identifying number), Suite \_\_\_\_ (the

identifying number) (if applicable) in the Briar Pointe Estates Condominiums Horizontal Property Regime" and include the date and recording data of the documents establishing the Horizontal Property Regime and any supplements thereto.

**5. Description of Condominium Units.**

**(a) Description of Units.** Each Unit shall consist of two (2) floors.

The Plans for Units 2011-1, 2011-2, 2025-1, 2025-2, 2037-1, 2037-2, 2704-1, 2704-2, 2726-1, and 2726-2 are attached as Exhibit "C-3", with the "1" Unit in each Building identified by the marking "1" and "2" Unit in each Building identified by the marking "2" on the Site Plan attached as Exhibit "C-2".

The Plans for Units 2044-1, 2044-2, 2049-1, and 2049-2 are attached as Exhibit "C-4", with the "1" Unit in each Building identified by the marking "#1" and "2" Unit in each Building identified by the marking "2" on the Site Plan attached as Exhibit "C-2".

The Plans for Units 2003 and 2727 are attached as Exhibit "C-5"

The description of any Units which are part of subsequent Phase(s) shall be set forth in Supplemental Declarations incorporating those Units into the Condominium development.

**(b) Appurtenances.** Each Condominium Unit shall consist of all space within the boundaries thereof, as hereinafter defined, and all portions of the Building in which it is located within such boundaries, including, without limitation, all fixtures, facilities, utilities, equipment, appliances, and structural components designed and intended solely and exclusively for the enjoyment, use and benefit of the Condominium Unit wherein the same are located, or to which they are attached, but excluding therefrom any such items that are designed or intended for the use, benefit, support, safety or enjoyment of any other Condominium Unit or which may be necessary for the safety, support, maintenance, use and operation of any of the Buildings or which are normally designed for common use; provided, however, that all fixtures, equipment and appliances designed or intended for the exclusive enjoyment, use and benefit of a Condominium Unit shall constitute a part of such Condominium Unit, whether or not the same are located within or partly within the boundaries of such Condominium Unit. The enclosed space of the attached garage connected to a Condominium Unit shall be included within such Unit. The driveways as shown upon the Plans are considered a part of and for the exclusive use of the Condominium Unit of such Building to which such garage appertains as indicated on the Plans and shall be considered as Limited Common Area as defined in Paragraph 7. The interior sides and surfaces of all doors and windows in the perimeter wall of a Condominium Unit, whether or not located within or partly within the boundaries of a Condominium Unit, and all interior walls (except load-bearing walls) and all of the floors

and ceiling within the boundaries of a Condominium Unit, are considered part of the Condominium Unit. All interior non-load bearing walls shall be a part of the Unit within which they are erected shall be moveable and not considered to be part of the Condominium Unit Boundary. The interior space of each covered patio shall be considered part of the Condominium Unit whether constructed as an extra room, enclosed porch or covered patio.

(c) **Boundaries.** The boundaries of each Condominium Unit shall be as shown on the Plans. The vertical boundaries shall run from the upper surfaces of the interior, unfinished surfaces of the lowest floors or subfloors to the interior unfinished surfaces of the highest ceilings and the horizontal boundaries shall be interior, unfinished surfaces or the common exterior and interior load-bearing walls (including windows and doors) of each Condominium Unit. Interior non-load-bearing walls shall be considered a part of the Unit, shall be considered moveable and shall not be considered a boundary of the Unit. In the event any horizontal, vertical or other boundary line as shown on the Plans does not coincide with the actual location of the respective wall, floor or ceiling surface of the Condominium Unit, because of inexactness of construction, settling after construction, Restoration, or any other reason, the boundary lines of each Condominium Unit shall be deemed to be and shall be treated for purposes of ownership, occupancy, possession, maintenance, decoration, use and enjoyment, as in accordance with the actual existing construction. In such case, permanent appurtenant easements for exclusive use shall exist in favor of the Owner of each Condominium Unit in and to such space lying outside of the actual boundary lines of the Condominium Unit, but within the appropriate wall, floor or ceiling surfaces of the Condominium Unit.

6. **Common Area and Facilities.** "Common Areas" and Facilities means:

(a) The land on which the Buildings shall be located.

(b) The foundations, columns, girders, beams, supports, main walls, roofs, entrances and exits and exterior wall surfaces of the Buildings.

(c) The storage spaces, open spaces, lakes, ponds, storm water pipes, inlets, manholes and other storm drainage improvements and facilities, woodland areas, sidewalks, streets, roads, except to the extent that the same are accepted for governmental maintenance, driveways, and parking areas, except to the extent the same are otherwise classified and defined herein as Limited Common Areas

(d) Central services installation for power, light, electricity, telephone, cable, gas, hot and cold water, lawn sprinkler systems, heating, air conditioning and sanitary sewer lines and mains serving the Condominium Units.

(e) Exterior lighting fixtures and electrical service lighting the exterior of the Buildings and certain of the other Common Areas unless separately metered to a particular Condominium Unit.

(f) Master television antenna or other telecommunication systems with connecting wiring and outlets to each Condominium Unit, if any.

(g) Pipes, ducts, insulation, electrical wiring and conduits and public utilities lines that serve more than one Condominium Unit; tanks, pipes, ducts, motors, fans, compressors apparatus and installations.

(h) Recreational facilities, if any, located on the Real Estate.

(i) Subfloors, ceilings and interiors of all structural walls, including all exterior perimeter and other load-bearing walls, walls between attached Condominium Units, walls and floors between the garage and the Condominium Unit, except to the extent the same are otherwise classified and defined herein as part of the Condominium Unit or Limited Common Areas.

(j) All structures, structural components, facilities and appurtenances of the Buildings located outside of the boundary lines of the Condominium Units, including those areas and facilities expressly classified and defined herein as Limited Common Areas but excluding such areas that are part of a Condominium Unit.

(k) All other parts of any parcel(s) of the Real Estate which have been expressly subjected to this Declaration of Condominium Ownership necessary or convenient to its existence, maintenance and safety or normal to its common use.

**7. Limited Common Areas and Facilities.** "Limited Common Areas" means those Common Areas and facilities to which use thereof is reserved to a Condominium Unit, as follows:

(a) The entrance ways through which access to a Condominium Unit is obtained shall be limited to the use of the Condominium Unit served by such entranceway.

(b) Patios, decks and unimproved porches, storage areas, if any, together with any area around such patios, deck or porches, or in the garage area or areas designated for use for landscaping by the Association, or otherwise, specifically shown and designated on the Plans as limited common areas and any fences and gates therein enclosing or surrounding the same, and the driveways and sidewalks serving a particular Condominium Unit to which there is direct access shall be limited to the use of the Condominium Unit served by such facilities.

(c) Air conditioning compressors, if any, attached to, or located in, a Building are limited to the use of the Condominium Units to which they are connected.

(d) The exterior sides and surfaces of doors, windows and frames surrounding the same in the perimeter walls in each Condominium Unit shall be limited to the exclusive use of the Condominium Unit to which they appertain.

(e) All lawns, trees, and landscaping lying outside the boundaries of any Unit, but which are appurtenant to a particular Unit shall be limited to the use and enjoyment of the Unit which is appurtenant to such lawns, trees and landscaping;

(f) Any other areas designated and shown on the Plans as Limited Common Areas or which lie outside the boundaries of any Unit and exclusively serve a particular Unit or Units shall be limited to the Condominium Unit or Condominium Units to which they appertain as shown on the Plans.

**8. Ownership of Common Area and Percentage Interest.** In connection with and as an inseparable part of the ownership of each Condominium Unit, each Owner thereof shall have an undivided interest in the Common Areas and Limited Common Areas as tenants in common with all other Owners, such interest to be equal to the Percentage Interest applicable to the Condominium Unit. Each Condominium Unit's Percentage Interest shall be a percentage equal to the square footage of the applicable Condominium Unit divided by the aggregate square footage of all Units which from time to time have been subjected and submitted to this Declaration and then constitute a part of the Briar Pointe Estates Condominiums. The initial Percentage Interest of each Condominium Unit, as determined by the above method, is set forth on Exhibit "E", attached hereto and made a part hereof. Such Percentage Interest shall be automatically reallocated upon the recordation of each Supplemental Declaration with plats and plans as Briar Pointe Estates Condominiums expands as herein provided. Such Percentage Interest shall not be severable and shall remain undivided. Except as otherwise provided or permitted herein, the Percentage Interest appertaining to each separate Condominium Unit in the Common Areas and Limited Common Areas shall be of a permanent nature and shall not be altered except in compliance with all requirements of the Act.

**9. Encroachments and Easements for Common Areas.** If, by reason of the location, construction, Restoration, settling or shifting of a Building, any Common Area or Limited Common Area now encroaches or shall hereafter encroach upon any Condominium Unit, then in such event, an easement shall be deemed to exist and run to the Owners and the Association for the maintenance, use and enjoyment of such Common Area or Limited Common Area.

Each Owner shall have an easement in common with the Owners of all other Condominium Units to use all pipes, wires, ducts, flues, cables, conduits, utility lines and other common facilities located in the Building in which the Owner's Unit is located and located in any of the other Condominium Unit(s) which serve his Condominium Unit.

Each Owner shall have the right to ingress and egress over, upon and across the Common Areas necessary for access to his Condominium Unit and any Limited Common Area designated for use in connection therewith and shall have the right to the horizontal and lateral support of his Condominium Unit. Such rights shall be appurtenant to and pass with the title to each Condominium Unit.

**10. Casualty and Restoration.** In the event of damage or destruction of the Property by fire or other cause, the following provisions shall be applicable:

(a) **Partial Destruction.** In the event less than all the Buildings are completely destroyed by the occurrence of fire or by other cause, then the Association shall cause the Property to be promptly repaired and restored in accordance with this Declaration and the original Plans and specifications. The proceeds of the insurance carried by the Association shall be applied to the cost of such Restoration. If the insurance proceeds are not adequate to cover the cost of Restoration, or in the event there are no proceeds, the cost for restoring the damage shall be paid by all of the Owners of the Condominium Units based on their Percentage Interest. If any Owner, or Owners, refuses or fails to make the required payments, the other Owners shall (or the Association, if such other Owners fail to do so) complete Restoration and pay the cost thereof, and the cost attributable to the Owner or Owners who refuse or fail to make such payments at the time required by the Board of Directors shall become a lien on such defaulting Owner's Condominium Unit and may be foreclosed in the same manner as provided for the lien for Common Expenses.

(b) **Complete Destruction.** In the event of complete loss or destruction of all the Buildings, this Regime shall terminate, the Property shall be deemed owned in common by the Owners and the provisions of the Indiana Code 32-25-8-12 shall apply.

(c) **Determination of Complete Destruction.** It shall be conclusively presumed that complete destruction of all Buildings did not occur unless it is determined by a Super Majority (sixty-seven percent (67%) of Owners) at a special meeting of the Association held within thirty days following the date of damage or destruction that all Buildings have been completely destroyed together with written consents of the Majority of Mortgagees. Such Super Majority of Owners may determine whether to rebuild, repair, restore or sell the Property.

(d) **Exception in Limited Common Areas.** Notwithstanding anything contained in this Declaration to the contrary, the Association shall have no obligation to repair or restore any improvements to the Property installed by a Unit Owner in the Limited Common Areas appurtenant to the Unit Owner's Unit.

11. **Association of Co-Owners.** Subject to the rights of Declarant reserved herein, and except as may provided to the contrary in this Declaration or the Bylaws, the maintenance, repair, upkeep, replacement, administration, management and operation of the Property shall be by the Association. Each Owner shall, automatically upon becoming an Owner of a Condominium Unit, be and become a member of the Association and shall remain a member until such time as his ownership ceases, but membership shall terminate when such Person ceases to be an Owner and will be transferred to the new Owner. In connection with membership in the Association, each Owner shall have a Percentage Vote which he shall be entitled to cast at each meeting of the Association on each matter on which the Owners may vote under the terms of this Declaration, the Articles of Incorporation of the Association, or the By-Laws. The Percentage Vote of the Owners shall be the same as the Owners respective Percentage Interests

Commencing upon the Applicable Date, the Association shall elect a Board of Directors annually (except for the Initial Board as defined in the By-Laws) in accordance with and as prescribed by the By-Laws. Each Owner shall be entitled to cast his Percentage Vote for the election of the Board of Directors, except for the Initial Board who shall serve for the period provided in the By-Laws. Each Person serving on the Initial Board, whether as an original member thereof or as a member thereof appointed by Declarant to fill a vacancy, shall be deemed a member of the Association and an Owner solely for the purposes of the Statute (as defined in the By-Laws) and of qualifying to act as a member of the Board of Directors and for no other purpose. No such Person serving on the Initial Board shall be deemed or considered a member of the Association nor an Owner for any other purpose (unless he is actually an Owner and thereby a member of the Association).

An individual designated by an Owner that is not a natural Person shall be deemed a member of the Association for the purpose of qualifying for membership on the Board of Directors.

The Board of Directors shall be the governing body of the Association, representing all the Owners in providing for the management, administration, operation, maintenance, repair, replacement and upkeep of the Property (exclusive of the Condominium Units except to the extent herein or in the By-Laws otherwise provided).

**12. Declarant's Use of Condominium Units.** Notwithstanding anything to the contrary contained herein or in the By-Laws, Declarant shall have, until the expiration of the period of time set forth in Paragraph 17 hereof as the date upon which Declarant's right to expand Briar Pointe Estates Condominiums terminates, the right to use and maintain any Condominium Units owned by Declarant, such other portions of the Property (other than individual Condominium Units owned by persons other than Declarant) and any portions of the Real Estate not then part of a Condominium Unit or the Limited Common Areas appurtenant to such Condominium Unit, all of such number and size and at such locations as Declarant in its sole discretion may determine, as Declarant may deem advisable or necessary in its sole discretion to aid in the renovation and sale of Condominium Units, or to promote or effect sales of Condominium Units, or for the conduct of any business or activity attendant thereto, including, without limitation, utilization of such property for model Condominium Units, storage areas, construction yards, signs, construction offices, sales offices, management offices and business offices. Declarant shall also have the right to rent or lease unsold Condominium unit(s) from time to time for such periods as it shall determine, in its sole exercise of discretion, without limitation. Declarant shall have the right to relocate any or all the same from time to time as it desires. At no time shall any of such facilities so used or maintained by Declarant be or become part of the Common Areas, unless so designated by Declarant, and Declarant shall have the right to remove the same from the Property at any time.

**13. Maintenance, Decoration, Repairs and Replacements.**

**a. Common Areas.** The Association will be responsible for the maintenance, repair, restoration, and replacement of the Common Areas, except as otherwise provided in this Declaration or the Bylaws. Maintenance, decoration, repairs, and replacements of the Common

Areas shall be furnished by the Association and the cost thereof shall be part of the Common Expenses. The Board of Directors has the right to adopt such rules and regulations concerning the maintenance, repairs, use and enjoyment of the Common Areas (including Limited Common Areas) as it deems appropriate, including the appointment of committees to oversee the same. The Board of Directors shall have the exclusive right to determine the outside decor of each Unit, including without limitation the color and type of paint and all other decor appurtenant to the exterior of each Unit. No Owner shall make any alteration or addition to the General Common Areas or the Limited Common Areas without the prior written approval of the Board of Directors. Swimming pools may not be installed by the Owners of any Units within Briar Pointe Estates Condominiums.

**b. Units.** Each Owner shall control and have the right to determine the interior decor of his Unit, but this shall not include the right to make structural changes to the Unit, nor the right to use interior decor which in the discretion of the Board of Directors adversely affects the external appearance of the Unit, as more particularly set forth in Section 14 of this Declaration. No act or omission which constitutes waste shall be committed or suffered in or upon any Unit, the General Common Areas or the Limited Common Areas. Each Owner shall maintain and repair at his sole cost and expense all fixtures, appliances, equipment, and other improvements constituting a part of his Unit, and each Owner shall promptly repair any condition or defect existing or occurring in his Unit which, if not repaired, might adversely affect any Unit or Common Area. In addition, each Owner shall furnish, and shall be responsible at his own expense for the maintenance, repairs and replacements of his Condominium Unit and appurtenant Limited Common Areas, and all equipment serving the same including any fencing installed around or in the Owner's Limited Common Areas, except to the extent otherwise provided herein or in the Bylaws; provided, however, the yard appurtenant to a Unit shall be maintained by the Association, unless the Board of Directors designates that the yard area inside a privacy fence is to be maintained by the Owner. In the case of a yard appurtenant to a Unit which is enclosed partially or completely by fencing which the Association maintains, the Unit Owner shall be subject to an additional charge as determined by the Board of Directors to account for any increase in mowing costs incurred by the Association in connection with such fenced in areas. The Association shall have the right to repair or replace any part of a Unit as may be reasonable and necessary to preserve the integrity of the Condominium and may charge the Unit Owner therefor and assess such Unit for the cost of such repair and/or replacement. In addition, the Association may, in its discretion, repair or replace any Limited Common Areas appurtenant to a particular Unit, including any fencing associated therewith, and assess the cost thereof to the Owner of such Unit. **Notwithstanding the foregoing, no Owner may install any fencing in or around his or her Limited Common Area or any other area appurtenant to that Owner's Unit with the prior written approval of the Board of Directors. In the event fencing is permitted, all fencing shall be uniform in design with all such fencing white vinyl, four feet in height.**

**14. Alterations, Additions and Improvements.** Except as is otherwise provided in this Declaration or the Bylaws, no Owner shall make any alterations, additions, or improvements to the Common Areas, including the Limited Common Areas, without the prior written approval of the Board of Directors, nor shall any Owner make any alterations to his respective Unit which would impair the safety thereof, or which would substantially alter or



adversely affect any structural portion of any Unit or impair any easement or hereditament, without the unanimous consent of the Owners. Any alteration, addition or improvement made by any Owner wholly or in part outside his respective Unit with the consent of the Board of Directors including any fencing installed by an Owner and/or any landscaping additions or other Board approved common area additions, or as otherwise permitted under this Declaration or the Bylaws, shall remain the property of that Owner and shall be owned, maintained and insured by that Owner as part of his Unit and deemed a part thereof for purposes of this Declaration. Upon the sale of his Unit, such alterations, additions, or improvements shall be transferred along with such Unit, and the purchaser shall be deemed to assume the prior Owner's maintenance and insurance obligations. If, in the reasonable discretion of the Board of Directors, such alteration, addition, or improvement is not being properly maintained, the Board of Directors or Managing Agent may perform any necessary maintenance work if such condition is not corrected by such Owner within ten (10) days after notice of such determination by the Board of Directors, and such Owner shall be liable for all costs incurred in connection with such maintenance, including attorneys' fees incurred in collection of the same. The provisions of this Paragraph 14, including the requirement for prior written Board approval shall also apply to Owners converting covered patios to screened in porches. However, sunroom additions shall not be permitted under any circumstances.

**15. Amendment of Declaration.** Except as otherwise provided in this Declaration or the Bylaws, amendments to this Declaration shall be proposed and adopted in the following manner:

(a) **Notice.** Notice of the subject matter of the proposed amendment shall be included in the notice of any meeting at which the proposed amendment is considered.

(b) **Resolution.** A resolution to adopt a proposed amendment may be proposed by the Board of Directors or Owners having in the aggregate at least a majority of the Percentage Vote.

(c) **Meeting.** The resolution concerning a proposed amendment must be adopted by the designated vote at a meeting duly called and held in accordance with the provisions of the By-Laws.

(d) **Adoption.** Except as otherwise provided herein, any proposed amendment to this Declaration must be approved by a Majority of Owners.

(e) **Restrictions Upon Amendments.**

(i) The unanimous consent of all Owners and the approval of all holders of all liens affecting any of the Condominium Units shall be required to (1) terminate the Regime, or (2) alter interests in the Common Areas or Limited Common Areas, except as is otherwise provided in Paragraph 17, below.

(ii) The consent of a Super Majority and the approval of the Majority of Mortgagees shall be required to amend materially any provisions of the

Declaration, By-Laws or equivalent organizational documents of the Regime or to add any material provisions thereto which establish, provide for, govern or regulate any of the following:

- (A) voting rights;
  - (B) increases in assessments that raise the previously assessed amount by more than twenty-five (25%) percent, assessment liens or subordination of such liens;
  - (C) reductions in reserves for maintenance, repair and replacement of the Common Areas;
  - (D) hazard or fidelity insurance requirements;
  - (E) responsibility for maintenance and repair;
  - (F) expansion or contraction of the Regime or the addition, annexation or withdrawal of property to or from the Regime, except as is provided in Paragraph 17 or Paragraph 18, below;
  - (G) redefinition of the boundaries for any Condominium Unit;
  - (H) the interest in the Common Areas or Limited Common Areas;
  - (I) convertibility of Condominium Units into Common Areas or Common Areas into Condominium Units;
  - (J) imposition of any restrictions on the leasing of Condominium Units, except that the Declarant's right to lease any unsold Units, at the sole discretion of the Declarant as provided in Paragraph 12, above, may not be restricted or amended in any manner without the written consent of the Declarant;
  - (K) imposition of any restriction on the right of an Owner to sell, transfer or otherwise convey his Condominium Unit;
  - (L) restoration or repair of the Property (after damage or partial condemnation) in a manner other than that specified in the Declaration, By-laws or equivalent documents of the Regime, or as prescribed pursuant to the Act.
- (iii) The consent of a Super Majority and the approval of the Majority of Mortgagees shall be required to amend any provisions included in the Declaration, By-Laws or the equivalent organizational documents of the Regime

that are for the express benefit of Mortgagees.

(f) **Recording.** Each amendment to the Declaration shall be executed by the President and Secretary of the Association provided that any amendment requiring the consent of Declarant shall contain Declarant's signed consent. All amendments shall be recorded in the office of the Recorder of Vanderburgh County, Indiana, and such amendment shall not become effective until so recorded.

(g) **Amendments by Declarant Only.** Notwithstanding the foregoing or anything elsewhere contained herein, the Declarant shall have the right acting alone and without the consent or approval of the Owners, the Association, the Board of Directors, any Mortgagees or any other Person to amend or supplement this Declaration from time to time if (i) such amendment or supplement is necessary to conform this Declaration to the Act, as amended from time to time, or (ii) such amendment or supplement is made to implement expansion of the Property and Briar Pointe Estates Condominiums pursuant to Declarant's reserved rights to so expand the same as set forth in Paragraph 17 hereof or to so contract the same as set forth in Paragraph 18 hereof, or (iii) such amendment or modification is necessary to conform this Declaration to requirements of applicable public authorities, or (iv) such amendment or supplement is made to comply with requirements of the Federal National Mortgage Association, the Government National Mortgage Association, the Federal Home Loan Mortgage Corporation, the Department of Housing and Urban Development, the Veterans Administration or any other governmental agency or any other public, quasi-public or private entity which performs (or may in the future perform) functions similar to those currently performed by such entities, or (v) to induce any of such agencies or entities to make, purchase, sell, insure or guarantee first mortgages, or (vi) if such amendment or supplement is made to correct clerical or typographical errors. In furtherance of the foregoing, a power coupled with an interest is hereby reserved and granted to the Declarant to vote in favor of, make, or consent to any amendments described in this Paragraph 15 on behalf of each Owner as proxy or attorney-in-fact, as the case may be.

Each deed, mortgage or other instrument affecting a Condominium Unit and the acceptance thereof shall be deemed to be a grant and acknowledgment of, and a consent to the reservation of, the power to the Declarant to vote in favor of, make, execute and record any such amendment, but the right of the Declarant to act pursuant to rights reserved or granted under this Paragraph 15 shall terminate at such time as the Declarant no longer holds or controls title to any part or portion of the Real Estate.

(h) **Amendment prior to the Applicable Date.** Notwithstanding anything contained herein to the contrary, prior to the Applicable Date, the Declarant or the Initial Board of Directors may amend this Declaration in any manner which does not violate the Act or any other applicable law.

16. **Acceptance and Ratification.** All present and future Owners, Mortgagees, tenants and occupants of the Condominium Units shall be subject to and shall comply with the provisions of this Declaration, the Act, the By-Laws appended hereto, and the rules and

regulations as adopted by the Board of Directors as each may be amended or supplemented from time to time. The acceptance of a deed of conveyance or the act of occupancy of any Condominium Unit shall constitute an agreement that the provisions of this Declaration, the Act, the By-Laws and rules and regulations as each may be amended or supplemented from time to time are accepted and ratified by such Owner, tenant or occupant, and all such provisions shall be covenants running with the land and shall bind any person having at any time any interest or estate in a Condominium Unit or the Property as though such provisions were recited and stipulated at length in each and every deed, conveyance, mortgage or lease thereof. All persons who may occupy, use, enjoy or control a Condominium Unit or Condominium Units or any part of the Property in any manner shall be subject to the Declaration, the Act, the By-Laws, and the rules and regulations applicable thereto as each may be amended or supplemented from time to time.

**17. Expandable Condominium and Declarant's Reserved Option Not to Expand.** Briar Pointe Estates Condominiums is and shall be an "expandable condominium", as defined in the Act, and Declarant expressly reserves the right and option to expand the Property and Briar Pointe Estates Condominiums, or to not expand, in accordance with the provisions of the Act and the following provisions:

(a) The land that shall be described and defined as Phase I on Exhibit "A" hereof shall be the land subjected to the Regime by this Declaration and shall constitute the first phase of the general development plan, containing such number of Buildings as Declarant shall elect. The Real Estate described as the "Briar Pointe Estates Condominiums Development Land" upon Exhibit "B" attached hereto is the area into which expansion of Briar Pointe Estates Condominiums may be made by Declarant and includes Phase I land. The maximum number of Condominium Units that may be developed in Phase I shall be Sixteen (16). Subject to said limit as to the maximum number of Condominium Units to be developed on Phase I of the Real Estate, Briar Pointe Estates Condominiums may be expanded by Declarant in one (1) or more additional Phases by the execution and recording of one (1) or more Supplemental Declarations with such additional Phases to result in no more than Sixty-Eight (68) Condominium Units in the entire Briar Pointe Estates Condominiums Regime; but no single exercise of such right and option of expansion as to any part or parts of the Development Land shall preclude Declarant from thereafter from time to time further expanding Briar Pointe Estates Condominiums to include other portions of the Real Estate, and such right and option of expansion may be exercised by Declarant from time to time as to all or any portions of Real Estate so long as additional Phases are developed and are added to the horizontal property regime within ten (10) years from date of recording hereof.

Such expansion is entirely at the discretion of Declarant, and nothing contained in this original Declaration or otherwise shall require Declarant to expand Briar Pointe Estates Condominiums to any portion of the Real Estate that Declarant may voluntarily and in its sole discretion from time to time subject to this Declaration by Supplemental Declarations as provided above.

(b) The Percentage Interest that will appertain to each Condominium Unit in Briar Pointe Estates Condominiums will be automatically altered from time to time by Declarant in accordance with the terms hereof (including the Percentage Interest that appertains to each of the Condominium Units included in this original Declaration) and shall be a percentage equal to equal to the square footage of the applicable Condominium Unit divided by the aggregate square footage of all Condominium Units which from time to time have been subjected and submitted to this Declaration and then constitute a part of the Briar Pointe Estates Condominiums.

(c) Simultaneously with the recording of Supplemental Declarations expanding Briar Pointe Estates Condominiums, Declarant shall record Plans as required by the Act. Such Supplemental Declarations shall also include provisions reallocating Percentage Interests so that the Condominium Units depicted on such new Plans shall be allocated Percentage Interests in the Common Areas and Limited Common Areas on the same basis as the Condominium Units depicted in the prior Plans. Such reallocation of Percentage Interests shall vest when each Supplemental Declaration incorporating those changes has been recorded.

(d) When the Supplemental Declaration incorporating the creation or addition of Condominium Units or expansion of Common Areas and Limited Common Areas, or both, is recorded, all liens including but not limited to mortgage liens shall be released as to the Percentage Interests in the Common Areas and Limited Common Areas described in this Declaration and shall attach to the reallocated Percentage Interests in the Common Areas and Limited Common Areas as though the liens had attached to those Percentage Interests on the date of the recordation of the mortgage or other lien. The Percentage Interests appertaining to additional Condominium Units being added by the Supplemental Declaration are subject to mortgages and liens upon the recordation of the Supplemental Declaration.

(d) In furtherance of the foregoing, a power coupled with an interest is hereby granted to and reserved by the Declarant, as attorney-in-fact, to shift the Percentage Interest in the Common Areas and Limited Common Areas appurtenant to each Condominium Unit to the percentages set forth in each Supplemental Declaration recorded pursuant to this Paragraph 17. Each deed, mortgage or other instrument with respect to a Condominium Unit and the acceptance thereof shall be deemed a consent to and acknowledgment of, and grant and/or reservation of (i) such power to said attorney-in-fact and (ii) the right pursuant to such power to shift and reallocate from time to time the percentages of ownership in the Common Areas and Limited Common Areas appurtenant to each Condominium Unit to the Percentages set forth in each such recorded Supplemental Declaration.

(e) Each Owner of a Condominium Unit by acceptance of a deed thereto, further acknowledges, consents and agrees, as to each recorded Supplemental Declaration, as follows:

(i) The portion of the Real Estate described in each such Supplemental Declaration shall be governed in all respects by the provisions of this Declaration.

(ii) The Percentage Interest in Common Areas and Limited Common Areas appurtenant to each Condominium Unit shall automatically be shifted and reallocated to the extent set forth in each Supplemental Declaration and upon the recording thereof such Percentage Interest shall thereby be and be deemed to be released and divested from such Owner and reconveyed and reallocated among the other Owners as set forth in each recorded Supplemental Declaration.

(iii) Each deed, mortgage or other instrument affecting a Condominium Unit shall be deemed given subject to the conditional limitation that the Percentage interest in the Common Areas and Limited Common Areas appurtenant to each Condominium Unit shall, upon the recording of each Supplemental Declaration, be divested by so much as the reduced percentage set forth in such Supplemental Declaration and vested among the other Owners, mortgagees and others owning an interest in the other Condominium Units in accordance with the terms and percentages of each such recorded Supplemental Declaration.

(iv) A right of revocation is hereby reserved by the grantor in each deed, mortgage or other instrument affecting a Condominium Unit to so amend and reallocate the Percentage Interest in the Common Areas and Limited Common Areas appurtenant to each Condominium Unit.

(v) The Percentage Interest in the Common Areas and Limited Common Areas appurtenant to each Condominium Unit shall include and be deemed to include any additional Common Areas and Limited Common Areas included in land to which Briar Pointe Estates Condominiums is expanded by a recorded Supplemental Declaration and each deed, mortgage or other instrument affecting a Condominium Unit shall be deemed to include such additional Common Areas and Limited Common Areas and the ownership of any such Condominium Unit and lien of and such mortgage shall automatically include and attach to such additional Common Areas and Limited Common Areas as such Supplemental Declarations are recorded.

(vi) Each Owner shall have a perpetual easement appurtenant to his Condominium Unit for the use of any additional Common Areas described in any recorded Supplemental Declaration, for the purposes therein set forth, except as to any portion the use of which is limited by exclusive easements granted in the Limited Common Areas to the Owners of specific Condominium Units as may be provided in such Supplemental Declaration, and each Owner of a Condominium Unit described in any recorded Supplemental Declaration shall have a perpetual easement appurtenant to his Condominium Unit for the use of all Common Areas (except Limited Common Areas) described in this Declaration as supplemented or

amended prior to the date of such recorded Supplemental Declaration.

(vii) Each Owner, by acceptance of the deed conveying his Condominium Unit, agrees for himself and all those claiming under him, including mortgagees, that this Declaration and each Supplemental Declaration are and shall be deemed to be in accordance with the Act and, for the purposes of this Declaration and the Act, any change in the respective Percentage Interests in the Common Areas and Limited Common Areas as set forth in each such Supplemental Declaration shall be deemed to be made by agreement of all Owners.

(viii) Each Owner agrees to execute and deliver such documents necessary or desirable to cause the provisions of this Paragraph 17 to comply with the Act as it may be amended from time to time.

(ix) Assessments, method of payment and enforcement thereof on Condominium Units built as an expandable Condominium Unit pursuant to any Supplemental Declaration shall be governed by the same provisions pertaining to Assessments as set forth in the By-Laws.

(x) Voting rights of an Owner in an expandable Condominium Unit created by Supplemental Declaration shall vest upon becoming a Member of the Association as prescribed by the By-Laws.

(g) In the event Declarant elects to expand the Property and Briar Pointe Estates Condominiums, all improvements constructed on the Real Estate shall be consistent with the general development plan and the improvements constructed on each expansion parcel (one or more of which may be referred to herein in the singular as the "Development Land") shall be consistent with the improvements then located on the Real Estate and forming a part of the Regime in terms of structure type and the quality of construction with the exception that the Declarant at its sole option may construct town house buildings and/or apartment buildings with similar quality of construction upon any portion of the Real Estate not previously subjected to this Regime by this Declaration or any supplemental Declaration thereto. No lien arising in connection with Declarant's Ownership of, and construction of improvements on, any such Development Land shall adversely affect the rights of existing Owners or the priority of first mortgages on Condominium Units in the existing Property. All taxes and other assessments relating to the Development Land covering any period prior to the addition of the Development Land shall be paid by or otherwise satisfactorily provided for by Declarant.

18. **Contractable Condominium.** Briar Pointe Estates Condominiums is and shall be a "Contractable Condominium", as defined in the Act, and Declarant expressly reserves the right and option to contract the Condominium by withdrawing any portion of the Real Estate described as the " Briar Pointe Estates Condominiums Development Land" on Exhibit "B" that is owned by the Declarant and has not been subjected to the Regime by this Declaration, or by any Supplemental Declaration(s) thereto, from this Declaration of Condominium and from the

General Development Plan, at any time and from time to time, subject to the following:

(a) The option of the Declarant to so contract the Condominium shall expire ten (10) years from the recording of this Declaration.

(b) The real estate subject to being withdrawn shall consist of any portion of the Real Estate described on Exhibit "B" as Briar Pointe Estates Condominiums Development Land owned by the Declarant which was not previously submitted to this Regime by this Declaration or by any Supplemental Declaration(s) thereto.

(c) The Declarant may withdraw the withdrawable real estate from the Condominium by preparing and filing with the County Recorder an amendment to this Declaration and Condominium instruments containing a legally sufficient description of the real estate being withdrawn from Briar Pointe Estates Condominiums Development Land and stating the fact of withdrawal.

(d) The Declarant may withdraw portions of the withdrawable land at different times.

19. **Granting and Amendment of Easements.** After the Applicable Date, the Board of Directors is granted the authority to grant such easements and to amend easements encumbering the Common Areas upon such terms and conditions and for such consideration as they deem appropriate. Prior to the Applicable Date, such authority shall remain vested in the Declarant.

20. **Reserved Rights, Street, Facilities and Other Easements.**

(a) Declarant shall have, and hereby reserves, an easement over, across, upon, along, in, through and under the Common Areas including any private roads and, including, to the extent necessary, the Limited Common Areas, for the purposes of installing, maintaining, repairing, replacing, relocating, extending and otherwise servicing all customary and necessary public utility facilities and installations to serve the Property and any portions of the Real Estate that are not part of the Property, including but not limited to water, sanitary sewer, electricity, telephone, cable television or other telecommunication services, as originally installed or as such may be improved or modified from time to time; to provide access to ingress and egress to and from the Property and to any such portions of Real Estate that are not part of the Property; to make sidewalk improvements, and repairs thereto, within the Property and any such portions of the Real Estate that are not part of the Property, and to provide for the rendering of public and quasi-public services to the Property and such portions of the Real Estate that are not part of the Property. The foregoing easement shall be a transferable easement, and, as reasonably requested by public or private utility companies or other applicable Persons, Declarant may at any time and from time to time without the necessity of consent or approval by any Owner(s) or their lien holders, the Association or the Board of Directors grant and convey such easements by separate instruments to establish and confirm such easement rights to the satisfaction of such public or private utility companies or other



Persons for the same purposes. By way of example, but not in limitation of the generality of the foregoing, Declarant, and others to whom Declarant may grant such similar easements, rights or privileges, may so use the Common Areas including any private roads and, to the extent necessary, the Limited Common Areas, to supply utility and telecommunication services to the Property and any portions of the Real Estate that are not part of the Property and to permit public and quasi-public vehicles, including but not limited to police, fire and other emergency vehicles, trash and garbage collection, post office vehicles and privately owned delivery vehicles, and their personnel to enter upon and use the drives and streets, the Common Areas and, to the extent necessary, the Limited Common Areas of Briar Pointe Estates Condominiums in the performance of their duties.

(b) Vehicular parking shall not be allowed in the right of way of the streets adjacent to the Property or in any private streets and shall be strictly limited to the garages and driveways appurtenant to each Condominium Unit. The Owners shall maintain driveways and parking areas as part of their Limited Common Areas.

(c) The Declarant shall have the right at all times to maintain one or more of the Condominium Units as a sales office or model and, at Declarant's sole option, to rent any unsold units provided that, tenants occupying such Units are required to abide by the By-Laws and the rules and regulations pursuant thereto.

21. **Initial Management.** As set forth in the By-Laws, the Initial Board of Directors has entered, or may hereafter enter, into a management agreement with Declarant (or a corporation or other entity affiliated with Declarant), or its assignee, or such other management company as the Initial Board of Directors deems appropriate, for a term which will expire not later than the Applicable Date, under which Declarant (or such affiliate of Declarant, as appropriate), or its assignee, will provide supervision, fiscal and general management and maintenance of the Common Areas, and, to the extent the same is not otherwise the responsibility of Owners of individual Condominium Units, the Limited Common Areas, and, in general, perform all of the duties and obligations of the Association. Such management agreement is or will be subject to termination by Declarant (or its affiliate, or assignee, as appropriate) at any time prior to the expiration of its term, in which event the Association shall thereupon and thereafter resume performance of all its duties and obligations and functions. Notwithstanding anything to the contrary contained herein, so long as such management agreement remains in effect, Declarant (or its affiliate, or assignee, as appropriate) shall have, and Declarant hereby reserves to and for its benefit (or to its affiliate, or other assignee as appropriate), the exclusive right to manage the Property and to perform all the functions of the Association.

The Initial Board may extend the management agreement beyond the Applicable Date providing the contract includes a right of termination without cause that the Association can exercise at any time after the Applicable Date. Any professional management contract, including without limitation any such contract with Declarant, or its assignee, shall not require the payment of any penalty or an advance notice of more than ninety (90) days as a condition to the right of termination. Both the term and termination provisions apply only to professional management

contracts and not to any other types of service contracts.

**22. Restrictions, Rules and Regulations.**

(a) **Restrictions on Use.** These covenants and restrictions upon the use and enjoyment of Condominium Units, Common Areas, Limited Common Areas and the Property are for the mutual benefit and protection of the present and future Owners and shall run with the land and inure to the benefit of and shall be enforceable by any Owner, or the Association. Present or future Owners and the Association shall be entitled to injunctive relief against any violation or attempted violation of these provisions and shall be entitled to damages for and injuries resulting from any violations thereof, but there shall be no right of reversion or forfeiture of title resulting from such violation. Such covenants and restrictions upon use are hereby imposed upon Briar Pointe Estates Condominiums:

i. All Condominium Units shall be exclusively for residential purposes and for occupancy by a single family or by no more than four (4) unrelated persons. No profession, business, trade or nonresidential activity shall be conducted in any Unit or upon any Common Area or Limited Common Area excepting that the Declarant specifically reserves the right to use a Condominium Unit as a sales office or sales area.

ii. Except as is otherwise provided herein or in the Bylaws, no additional buildings shall be erected or located on the Property other than the Buildings designated in the Declaration, or a supplement, or amendment to the Declaration and shown on the Plans or plans hereafter filed with such a supplement or amendment to the Declaration, without the consent of the Board of Directors, excepting Declarant reserves the right to maintain a mobile office for construction, marketing or management and the right to add recreational structures or a building at a location selected by the Declarant.

iii. Nothing shall be done or kept in any Condominium Unit or in the Common Areas or Limited Common Areas that will cause an increase in the rate of insurance on any Building or the contents thereof. No Owner shall permit anything to be done or kept in his Condominium Unit or in the Common Areas or Limited Common Areas that will result in a cancellation of insurance on any building or any part of the Common Areas or contents thereof, or that should be in violation of any law or ordinance or the requirements of any insurance underwriting or rating bureau.

iv. Vehicular parking shall not be allowed in the right-of-way of the streets adjacent to the Property and not in any private streets and shall be limited strictly to garages and driveways appurtenant to Units as is provided in subparagraph (vi), below.

v. No Owner shall cause or permit the alteration in any way of the

exterior appearance of the Buildings or the landscaping upon the Common Areas other than any landscaping of the Limited Common Areas appurtenant to the Owner's Unit.

vi. The storage or parking of any boats, trailer or other property upon any of the Common Areas or Limited Common Areas, including driveways and public or private roads, is prohibited. All passenger vehicles of Owners and occupants of the Units, when not in use, shall be parked in the garage provided with each Unit, and the garage doors shall remain closed except when a passenger vehicle is entering or exiting from the garage; provided, however, if the Unit does not have sufficient garage spaces to house all of the passenger vehicles of the Owner and occupant, those vehicles for which there is no garage space shall be parked in the driveway appurtenant to such Unit.

vii. No nuisance shall be permitted and no waste shall be committed in any Condominium Unit, Common Areas or Limited Common Areas.

viii. No Owner shall cause or permit anything to be hung or displayed on the outside of the windows or placed on the outside walls of any Building, and no sign, awning, canopy, shutter or radio or television antenna or other attachment or thing shall be affixed to or be placed upon the exterior walls or roofs or any other parts of any Building without the prior consent of the Board. Interior window and door drapes or coverings shall be of a neutral translucent color and texture or of the same color of the exterior facade surrounding the window or door.

ix. No signs shall be permitted within Briar Pointe Estates Condominiums except the following:

(a) The owner of any Unit who desires to sell said Unit shall be permitted to place a "FOR SALE" sign in the front yard area constituting that Owner's Limited Common Areas; and

(b) Unit Owners may display in the front yard area constituting the Owner's Limited Common Areas one (1) sign indicating that their Unit is protected by a "commercial home security system"; provided, however, such sign may not exceed 12" by 12" in size and each front yard area may not contain more than one (1) such sign at any one time. For purposes of the immediately preceding sentence "commercial home security system" shall mean a security system which the Unit Owner has purchased from a business engaged in the sale of home security systems to homeowners. Signs such as "Beware of Dog", "Home Protected by 357 Magnum", "No Trespassing" and similar signs are specifically not included within the definition of "commercial security system" as

used in this subsection (b) and are not permitted within Briar Pointe Estates Condominiums.

x. Nothing shall be done or permitted in any Condominium Unit that will impair the structural integrity of any Building or that would structurally change any Building or that would affect the exterior appearance of any Condominium Unit, except as otherwise provided in the Declaration or these By-Laws.

xi. No Condominium Unit shall be used in any unlawful manner or in any manner that might cause injury to the reputation of Briar Pointe Estates Condominiums or that might be a nuisance or damage to other Owners and occupants of Condominium Units or neighboring property, including without limiting the generality of the foregoing, noise by the use of any loudspeakers, electrical equipment, amplifiers or other equipment or machines or loud persons.

xii. The Common Areas and Limited Common Areas shall be kept free and clear of rubbish, debris and other unsightly materials. No clothes, sheets, blankets, rugs, laundry or other things shall be hung out or exposed on any part of the Common Area or Limited Common Areas.

xiii. All Owners, guests, tenants or invitees, and all occupants of any Condominium Units or other Persons entitled to use the same and to use and enjoy the Common Areas and Limited Common Areas or any part thereof, shall observe and be governed by such rules and regulations as may from time to time be promulgated and issued by the Board governing the operation, use and enjoyment of the Condominium Units, the Common Areas and Limited Common Areas; including but not limited to rules relating to the keeping of animals, the parking or storage of vehicles or trailers and other matters incidental to the use of the Common Areas and Limited Common Areas.

xiv. With respect to any lakes or parts thereof which are located within the Real Estate, Unit Owners and their guests may access the lake(s) subject to the following:

(a) To the extent a Unit Owner lives adjacent to the lake, that Unit Owner and his or her guests shall access the lake over that Unit Owner's Limited Common Area. Unit Owners who do not live adjacent to the lake, and their guests, shall access the lake from over any Common Area adjacent to the lake, provided, however, "Common Area adjacent to the lake" shall not include the Limited Common Area of an Owner who lives adjacent to the lake.

(b) Unit Owners must accompany their guests at all times;

- (c) There shall be no usage of any motorized watercraft that can expel any oil or gas products, including, without limitation, "Personal Watercraft" as defined by applicable Indiana law (i.e. waverunners, jet skis or their equivalent) on any lake.
- (d) Only one (1) non-motorized watercraft belonging to any Unit Owner or his or her guests shall be permitted upon any lake at any time.
- (e) No access to any lake through or over any portion of any Unit Owner's Limited Common Areas may be sold, leased, rented or otherwise transferred to any other person by the Unit Owner, separate from the sale of the Unit Owner's Unit.
- (f) Use of any lake within the Real Estate shall be at the risk and liability of the Unit Owners, other than the Declarant. Said Unit Owners shall indemnify, defend and hold harmless the Declarant from any and all liabilities, obligations, indebtedness, costs, expenses, attorney fees or judgments arising out of, resulting from, related to or connected with any use, whether authorized or unauthorized, of any lake which is wholly or partially contained within the Real Estate.

xv. No Owner shall be allowed to plant trees, landscape or do any gardening in any of the Common Areas, other than any landscaping of the Limited Common Areas appurtenant to the Owner's Unit, except with prior written permission from the Board.

xvi. No Owner shall be allowed to place or cause to be placed or stored on the Common Areas, any furniture or objects of any kind, without consent of the Board, other than the Limited Common Areas appurtenant to the Owner's Unit.

xvii. All garbage, trash and refuse shall be stored in appropriate containers inside the Condominium Unit (including the garage) or behind the Condominium Unit but not visible from the front of the Condominium Unit, and not in any entrance way and shall be kept therein until not earlier than sundown of the evening before scheduled trash collection and shall be placed at such locations for trash collection as are designated by the Board for collection.

xviii. Common Areas and Limited Common Areas shall be used only for the purposes for which they are designated and intended and shall be used subject to the provisions of the Declaration, these By-Laws and the rules and regulations from time to time adopted by the Board.

xix. The Condominium Owners Association shall have the right to eject

or evict any non-owner(s) who is/are occupying a Unit, pursuant to a written lease or otherwise, not in compliance with such restrictions, rules and regulations of the Association from any condominium unit pursuant to appropriate legal proceedings.

xx. No Owners shall cause or permit any alteration or structural change to his Unit that would jeopardize the soundness or safety of the Unit or Building in which it is located or reduce the value of the Unit or Building or impair any easement or hereditament.

xxi. There shall be no obstruction of the Common Areas nor shall anything be stored in or about the Common Areas without the consent of the Board of Directors of the Association, except as is otherwise provided in this Declaration.

xxii. No animals, other than common household pets, shall be kept or maintained in any Unit and no such pets shall be kept or maintained on the outside of any Unit. No such pets shall be permitted to roam freely, and each shall be on a leash when outside the Owner's Unit. No pets shall be kept, bred or maintained for commercial purposes. Owners and their family and guests shall clean up after their pet and dispose of excrement in proper trash facilities. No more than two (2) pets shall be permitted per Unit.

xxiii. All Owners, guests, tenants, or invitees and all occupants of any Condominium Units or other persons entitled to use the same and to use and enjoy the Common Areas and Limited Common Areas, or any part thereof, shall observe and be governed by such rules and regulations as may be from time to time promulgated and issued by the Board governing the operation, use and enjoyment of the Condominium Units, the Common Areas and Limited Common Areas. The Association shall have the right to prohibit, limit, or impose restrictions upon access to the Condominiums by solicitors and sales' persons. Common Areas and Limited Common Areas shall be used only for the purposes for which they are designated and intended and shall be used subject to the provisions of the Declaration, the By-Laws and the rules and regulations from time adopted by the Board. The Condominium Owners Association shall have the right to evict or eject pursuant to appropriate legal proceedings any individuals not in compliance with the Declaration, By-Laws and rules and regulations of the Association.

xxiv. Each Owner hereby waives his or her right to remonstrate against, or in connection with, any rezoning filed by the Briar Pointe Development, LLC and/or its successors and assigns on any portion of Briar Pointe Subdivision or any property adjacent to Briar Pointe Subdivision, including without limitation any future sections of Briar Pointe Subdivision.

xxv. No pole barns or yard barns and no structure of a temporary

character, trailer, tent, shack, garage, barn or other outbuilding shall be installed, constructed, placed or used on any Common Areas, including any Limited Common Areas appurtenant to a Unit Owner's Unit, or any part thereof at any time, either temporarily or permanently.

(b) **Right of Board to Adopt Rules and Regulations.** The Board may promulgate such rules and regulations regarding the operation of the Property, including but not limited to the use of the Common Areas and Limited Common Areas, as it may deem necessary from time to time and such rules as are adopted may be amended by a vote of a majority of the Board. The Board shall cause copies of such rules and regulations and all amendments thereto to be delivered or mailed promptly to all Owners.

(c) **Enforcement.** The Declarant, the Board, or, in a proper case, an aggrieved Owner shall have the right of enforcement of all restrictions and regulations adopted pursuant to this Paragraph 22. Notwithstanding the foregoing, such enforcement actions shall, where applicable, be subject to the "Grievance Resolution" procedures set forth in IC 32-25-8.5-1, et. seq.

**23. Assessments and Limitation on Declarant's Liability for Assessments.** Co-Owners are obligated to contribute pro rata in the same percentage as their established Percentage Interest in Common Areas and Limited Common Areas set forth in Paragraph 8 of this Declaration to the payment of the Common Expenses and to the usual and ordinary maintenance and replacement reserve fund to assure continuous and adequate maintenance of Briar Pointe Estates Condominiums as prescribed by the Act, and the assessment procedures and the methods of collection and enforcement set forth under Article VI of the By-Laws attached to this Declaration. Provided, however, Declarant, or its successors in interest, as an Owner, shall be excused from payment of assessments from the date this Declaration is recorded until the first day of the twenty-fourth (24th) calendar month following the month in which the closing of the sale of the first Condominium Unit in a Phase occurs.

**24. Sale or Lease of Condominium Unit by Owner.**

(a) **Lease.** It is in the best interests of all the Owners that those persons residing in Briar Pointe Estates Condominiums have similar proprietary interests in their Condominium Units and be Owners. For the purpose of maintaining the congenial and residential character of Briar Pointe Estates Condominiums, no Unit Owner other than the Declarant, shall lease his Condominium Unit or enter into any other rental or letting arrangement for his Condominium Unit, without the prior written consent of the Board of Directors, unless such lease is in writing and is for a term of not less than six (6) successive calendar months. Any such lease shall be made explicitly subject to the terms of this Declaration and the By-Laws and require all tenants and their guests and invitees to comply with all provisions of this Declaration, the By-Laws and rules and regulations thereunder. The Declarant until the Applicable Date and the Association thereafter shall have the right and authority to terminate any such lease and evict any tenant of any Owner for repeated violations of any provisions of the Declaration or the By-Laws and the rules and regulations of the Association pursuant to appropriate legal proceedings and

such written lease shall provide notice to the tenant(s) of the existence of such right and authority. There shall be no restrictions or limitations on Declarant's right to rent or lease Units owned by Declarant including, without limitation, the minimum length of time for such arrangements

(b) **Sale.** The Association shall have no right of the first refusal to purchase any Condominium Unit which an Owner wishes to sell and an Owner may sell or lease his Condominium Unit free of any such restriction.

(c) **Statement of Regular or Special Assessments.** No less than five (5) business days prior to the sale of any Condominium Unit by an Owner other than the Declarant, such Owner must request the Board of Directors to issue a written statement of all assessed and unpaid Regular and Special Assessments due from such Owner in a form suitable for recording. The Board of Directors may by written Resolution by an instrument of incumbency, authorize one or more members of the Board, or the Treasurer of the Association, to sign such written statement. The recording of such written statement with a Unit Deed shall operate to discharge the Unit from any lien for any other Regular and Special Assessments unpaid as of the date of such statement.

25. **Right of Action.** Subject to the provisions of Paragraph 22(c), the Declarant, the Association and any aggrieved Owner (as further defined therein) shall have a right of action against any Owner or Owners for failure to comply with the provisions of the Declaration, By-Laws or any decision of the Association or its Board of Directors which are made pursuant to authority granted to the Association or its Board of Directors in such documents. Owners shall have similar right against the Association.

26. **Costs and Attorney's Fees.** In any proceeding arising because the failure of any Owner to make any payments required by this Declaration, the By-Laws or the Act, or to comply with any provision of the Declaration, the Act, or the By-Laws, or the rules and regulations adopted pursuant thereto as each may be amended from time to time, the party initiating the enforcement action shall be entitled to recover its costs and reasonable attorneys' fees incurred in connection with such default or failure.

27. **Waiver.** No Owner may exempt himself from liability for his contribution toward the Common Expenses by waiver of the use or enjoyment of any of the Common Areas or Limited Common Areas or by abandonment of his Condominium Unit.

28. **Severability.** The invalidity of any covenant, restriction, condition, limitation or other provisions of this Declaration or the By-Laws filed herewith shall not impair or affect in any manner the validity, enforceability or effect of the rest of this Declaration or the attached By-Laws.

29. **Rules of Interpretation.** Any reference to the masculine, feminine or neuter gender herein shall, unless the context clearly required the contrary, be deemed to refer to and include the masculine, feminine and neuter genders. Words in the singular shall include and refer to the plural, and vice versa, as appropriate.



**30. Exculpation.** This instrument is executed and delivered on the express condition that anything herein to the contrary notwithstanding, each and all of the representations, covenants, undertakings and agreements herein made on the part of Declarant ("Representations"), while in form purporting to be the representations of Declarant, are nevertheless each and every one of them, made and intended not as personal representations by Declarant or for the purpose or with the intention of binding Declarant personally, but are made and intended for the purpose of binding only the portion of the Real Estate submitted to the Regime; and no personal liability or personal responsibility is assumed, and shall not at any time be inferred, asserted or enforceable against Declarant, personally, or its Members or Managers, on account of this instrument or on account of, in connection with, or arising out of any representations of Declarant in this instrument, either express or implied, all of such personal liability, if any, being expressly waived and released by each Person who acquired any interest in a Condominium Unit as a Condition to the acquisition thereof.

DECLARANT:

JOHN J. ELPERS CONTRACTING, INC.

By:   
\_\_\_\_\_  
John J. Elpers, President

STATE OF INDIANA )  
 ) SS:  
COUNTY OF VANDERBURGH )

Before me, the undersigned, a Notary Public in and for said County and State, personally appeared John J. Elpers, Jr., who being first duly sworn by his oath, stated that he is the President of John J. Elpers Contracting, Inc., an Indiana corporation, that he is duly authorized to execute the foregoing on its behalf, that any statements or representations of fact contained therein are true, and he acknowledged execution of the foregoing for and on behalf of said corporation.

WITNESS my hand and Notarial Seal this 15<sup>th</sup> day of May, 2024

My commission expires:  
Jan. 24, 2029

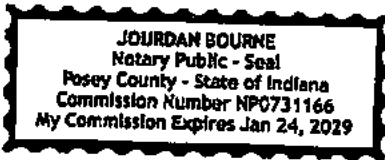

Jourdan Bourne  
Notary Public

Jourdan Bourne

Notary Name Printed

Notary Public is a resident of  
POSEY County, Indiana.

This instrument was prepared by Scott S. Stone, Stone & Stratman, LLP, P.O. Box 1135, Evansville, IN 47706; (812) 425-5345.

I affirm, under the penalties for perjury, that I have taken reasonable care to redact each Social Security number in this document, unless required by law. /s/ Scott S. Stone

## **Exhibit "A"**

### **LEGAL DESCRIPTION OF PHASE I**

Part of the West Half of Section 15, Township 6 South, Range 10 West; also, part of the Northeast Quarter of Section 16, Township 6 South, Range 10 West all in Center Township, Vanderburgh County, Indiana and being more particularly described as follows:

Commencing at the Northwest Corner of the Southwest Quarter of Section 10, Township 6 South, Range 10 West in Vanderburgh County, Indiana; thence along the north line of the Southwest Quarter of said Section 10, South 88 Degrees 36 Minutes 34 Seconds East 668.61 feet to a point on the extended west right-of-way of Maxx Road as granted to the City of Evansville in Deed Drawer 4, card 6400 in the Office of said Recorder; thence along the extended west line and the west right-of-way of said Maxx Road, South 00 Degrees 41 Minutes 31 Seconds East 2637.31 feet to a point on the north line of the West Half of said Section 15; thence along said north line, South 88 Degrees 33 Minutes 34 Seconds East 30.02 feet to the center of Maxx Road; thence along the center of Maxx Road, South 00 Degrees 41 Minutes 31 Seconds East 1334.58 feet to the point of beginning; thence continue along the center of Maxx Road, South 00 Degrees 41 Minutes 31 Seconds East 733.26 feet; thence North 26 Degrees 38 Minutes 19 Seconds West 36.98 feet; thence North 59 Degrees 46 Minutes 28 Seconds West 34.49 feet; thence North 22 Degrees 56 Minutes 52 Seconds West 40.09 feet; thence North 06 Degrees 38 Minutes 19 Seconds East 45.94 feet; thence North 72 Degrees 14 Minutes 48 Seconds West 63.44 feet; thence North 46 Degrees 32 Minutes 20 Seconds West 90.83 feet; thence North 63 Degrees 39 Minutes 30 Seconds West 127.61 feet; thence South 87 Degrees 39 Minutes 12 Seconds West 54.37 feet; thence South 71 Degrees 32 Minutes 20 Seconds West 61.66 feet; thence South 87 Degrees 19 Minutes 42 Seconds West 39.26 feet; thence South 71 Degrees 18 Minutes 48 Seconds West 41.61 feet to a point in the center of Pigeon Creek; thence along the center of said creek the following four (4) calls:

thence North 40 Degrees 10 Minutes 50 Seconds West 180.28 feet;  
thence North 39 Degrees 21 Minutes 59 Seconds West 183.11 feet;  
thence North 34 Degrees 59 Minutes 27 Seconds West 98.17 feet;  
thence North 30 Degrees 49 Minutes 44 Seconds West 80.00 feet;

thence North 72 Degrees 16 Minutes 32 Seconds East 167.91 feet; thence North 85 Degrees 47 Minutes 38 Seconds East 85.16 feet; thence South 59 Degrees 57 Minutes 23 Seconds East 226.32 feet; thence North 34 Degrees 54 Minutes 57 Seconds East 172.75 feet; thence North 68 Degrees 46 Minutes 11 Seconds East 83.13 feet; thence South 84 Degrees 50 Minutes 17 Seconds East 59.83 feet; thence South 67 Degrees 35 Minutes 17 Seconds East 35.25 feet; thence South 61 Degrees 34 Minutes 04 Seconds East 57.36 feet; thence North 89 Degrees 18 Minutes 29 Seconds East 50.00 feet to the point of beginning and containing a gross area of 7.636 acres, more or less.

## EXHIBIT "B"

### Briar Pointe Estates Condominium Areas

#### Original Area:

##### Area A

Part of the West Half of Section 15, Township 6 South, Range 10 West; also, part of the Northeast Quarter of Section 16, Township 6 South, Range 10 West all in Center Township, Vanderburgh County, Indiana and being more particularly described as follows:

Commencing at the Northwest Corner of the Southwest Quarter of Section 10, Township 6 South, Range 10 West in Vanderburgh County, Indiana; thence along the north line of the Southwest Quarter of said Section 10, South 88 Degrees 36 Minutes 34 Seconds East 668.61 feet to a point on the extended west right-of-way of Maxx Road as granted to the City of Evansville in Deed Drawer 4, card 6400 in the Office of said Recorder; thence along the extended west line and the west right-of-way of said Maxx Road, South 00 Degrees 41 Minutes 31 Seconds East 2637.31 feet to a point on the north line of the West Half of said Section 15; thence along said north line, South 88 Degrees 33 Minutes 34 Seconds East 30.02 feet to the center of Maxx Road; thence along the center of Maxx Road, South 00 Degrees 41 Minutes 31 Seconds East 1334.58 feet to the point of beginning; thence continue along the center of Maxx Road, South 00 Degrees 41 Minutes 31 Seconds East 733.26 feet; thence North 26 Degrees 38 Minutes 19 Seconds West 36.98 feet; thence North 59 Degrees 46 Minutes 28 Seconds West 34.49 feet; thence North 22 Degrees 56 Minutes 52 Seconds West 40.09 feet; thence North 06 Degrees 38 Minutes 19 Seconds East 45.94 feet; thence North 72 Degrees 14 Minutes 48 Seconds West 63.44 feet; thence North 46 Degrees 32 Minutes 20 Seconds West 90.83 feet; thence North 63 Degrees 39 Minutes 30 Seconds West 127.61 feet; thence South 87 Degrees 39 Minutes 12 Seconds West 54.37 feet; thence South 71 Degrees 32 Minutes 20 Seconds West 61.66 feet; thence South 87 Degrees 19 Minutes 42 Seconds West 39.26 feet; thence South 71 Degrees 18 Minutes 48 Seconds West 41.61 feet to a point in the center of Pigeon Creek; thence along the center of said creek the following four (4) calls:

thence North 40 Degrees 10 Minutes 50 Seconds West 180.28 feet;  
thence North 39 Degrees 21 Minutes 59 Seconds West 183.11 feet;  
thence North 34 Degrees 59 Minutes 27 Seconds West 98.17 feet;  
thence North 30 Degrees 49 Minutes 44 Seconds West 80.00 feet;

thence North 72 Degrees 16 Minutes 32 Seconds East 167.91 feet; thence North 85 Degrees 47 Minutes 38 Seconds East 85.16 feet; thence South 59 Degrees 57 Minutes 23 Seconds East 226.32 feet; thence North 34 Degrees 54 Minutes 57 Seconds East 172.75 feet; thence North 68 Degrees 46 Minutes 11 Seconds East 83.13 feet; thence South 84 Degrees 50 Minutes 17 Seconds East 59.83 feet; thence South 67 Degrees 35 Minutes 17 Seconds East 35.25 feet; thence South 61 Degrees 34 Minutes 04 Seconds East 57.36 feet; thence North 89 Degrees 18 Minutes 29 Seconds East 50.00 feet to the point of beginning and containing a gross area of 7.636 acres, more or less.

## **Possible Expansion Area:**

### **Area 1**

Part of the Southeast Quarter of Section 9, Township 6 South, Range 10 West; also, part of the Northeast Quarter of Section 16, Township 6 South, Range 10 West in Center Township, Vanderburgh County, Indiana and being more particularly described as follows:

Commencing at the Northwest Corner of the Southwest Quarter of Section 10, Township 6 South, Range 10 West in Vanderburgh County, Indiana; thence along the north line of the Southwest Quarter of said Section 10, South 88 Degrees 36 Minutes 34 Seconds East 668.61 feet to a point on the extended west right-of-way of Maxx Road as granted to the City of Evansville in Deed Drawer 4, card 6400 in the Office of said Recorder; thence along the extended west line and the west right-of-way of said Maxx Road, South 00 Degrees 41 Minutes 31 Seconds East 2637.31 feet to a point on the south line of the West Half of said Section 10; thence along said south line, North 88 Degrees 33 Minutes 34 Seconds West 650.35 feet to the Northeast Corner of said Section 16, Township 6 South, Range 10 West; thence along the north line of the Northeast Quarter of said Section 16, North 88 Degrees 42 Minutes 01 Second West 836.27 feet to the point of beginning; thence

South 00 Degrees 13 Minutes 50 Seconds West 27.58 feet; thence South 16 Degrees 55 Minutes 50 Seconds West 49.13 feet; thence South 02 Degrees 57 Minutes 15 Seconds West 46.35 feet; thence South 37 Degrees 12 Minutes 18 Seconds West 60.17 feet; thence South 01 Degree 15 Minutes 36 Seconds East 77.24 feet; thence South 65 Degrees 46 Minutes 21 Seconds West 54.07 feet; thence South 54 Degrees 47 Minutes 59 Seconds West 53.18 feet; thence South 07 Degrees 00 Minutes 30 Seconds West 43.62 feet; thence South 29 Degrees 36 Minutes 29 Seconds West 37.99 feet; thence South 29 Degrees 08 Minutes 57 Seconds West 42.86 feet to a point in the center of Pigeon Creek; thence along the center of said creek the following five (5) calls:

North 59 Degrees 49 Minutes 07 Seconds West 98.83 feet; thence North 62 Degrees 02 Minutes 12 Seconds West 240.35 feet; thence North 62 Degrees 56 Minutes 53 Seconds West 192.13 feet; thence North 67 Degrees 30 Minutes 22 Seconds West 137.70 feet; thence North 73 Degrees 30 Minutes 50 Seconds West 109.08 feet; thence leaving said centerline, North 12 Degrees 44 Minutes 33 Seconds West 88.63 feet; thence North 28 Degrees 40 Minutes 34 Seconds West 53.10 feet; thence North 01 Degree 19 Minutes 38 Seconds West 45.15 feet; thence North 37 Degrees 51 Minutes 50 Seconds West 46.71 feet; thence North 03 Degrees 17 Minutes 22 Seconds East 85.31 feet; thence North 21 Degrees 48 Minutes 50 Seconds East 61.80 feet; thence North 32 Degrees 50 Minutes 24 Seconds East 55.71 feet; thence North 18 Degrees 53 Minutes 01 Second East 65.45 feet; thence North 67 Degrees 58 Minutes 03 Seconds East 62.04 feet; thence

North 45 Degrees 25 Minutes 15 Seconds East 74.82 feet; thence  
North 01 Degree 25 Minutes 50 Seconds East 71.47 feet; thence  
South 88 Degrees 34 Minutes 10 Seconds East 102.22 feet to the beginning of a curve to the left  
having a central angle of 90 Degrees 00 Minutes 00 Seconds, a radius of 75.00 feet and a chord  
dimension of North 46 Degrees 25 Minutes 50 Seconds East 106.07 feet; thence  
along the arc of said curve 117.81 feet; thence  
North 01 Degree 25 Minutes 50 Seconds East 94.51 feet to the beginning of a curve to the right  
having a central angle of 90 Degrees 00 Minutes 00 Seconds, a radius of 25.00 feet and a chord  
dimension of North 46 Degrees 25 Minutes 50 Seconds East 35.36 feet; thence  
along the arc of said curve 39.27 feet; thence  
South 88 Degrees 34 Minutes 10 Seconds East 402.54 feet to the beginning of a curve to the  
right having a central angle of 90 Degrees 00 Minutes 00 Seconds a radius of 25.00 feet and a  
chord dimension of South 43 Degrees 34 Minutes 10 Seconds East 35.36 feet; thence  
along the arc of said curve 39.27 feet; thence  
South 01 Degree 25 Minutes 50 Seconds West 49.32 feet to the beginning of a curve to the left  
having a central angle of 26 Degrees 25 Minutes 50 Seconds, a radius of 225.00 feet and a chord  
dimension of South 11 Degrees 47 Minutes 05 Seconds East 102.87 feet; thence  
along the arc of said curve 103.79 feet; thence  
South 25 Degrees 00 Minutes 00 Seconds East 187.57 feet to the beginning of a curve to the left  
having a central angle of 57 Degrees 03 Minutes 06 Seconds, a radius of 105.00 feet and a chord  
dimension of South 53 Degrees 31 Minutes 33 Seconds East 100.29 feet; thence  
along the arc of said curve 104.55 feet; thence  
South 07 Degrees 56 Minutes 54 Seconds West 52.65 feet; thence  
South 19 Degrees 00 Minutes 00 Seconds West 153.71 feet; thence  
South 00 Degrees 00 Minutes 00 Seconds West 32.81 feet; thence  
South 21 Degrees 52 Minutes 28 Seconds East 45.00 feet; thence  
South 00 Degrees 13 Minutes 50 Seconds West 36.41 feet to the point of beginning and  
containing a gross area of 17.478 acres, more or less.

**EXHIBIT "C-1"**

**GENERAL PLAN OF DEVELOPMENT FOR PHASE I AND AREAS  
INTO WHICH EXPANSION MAY BE MADE**

# General Plan of Development

**Original Area**  
Shown and labeled  
as Area A

**Possible  
Expansion Area**  
Shown and labeled as  
Area 1

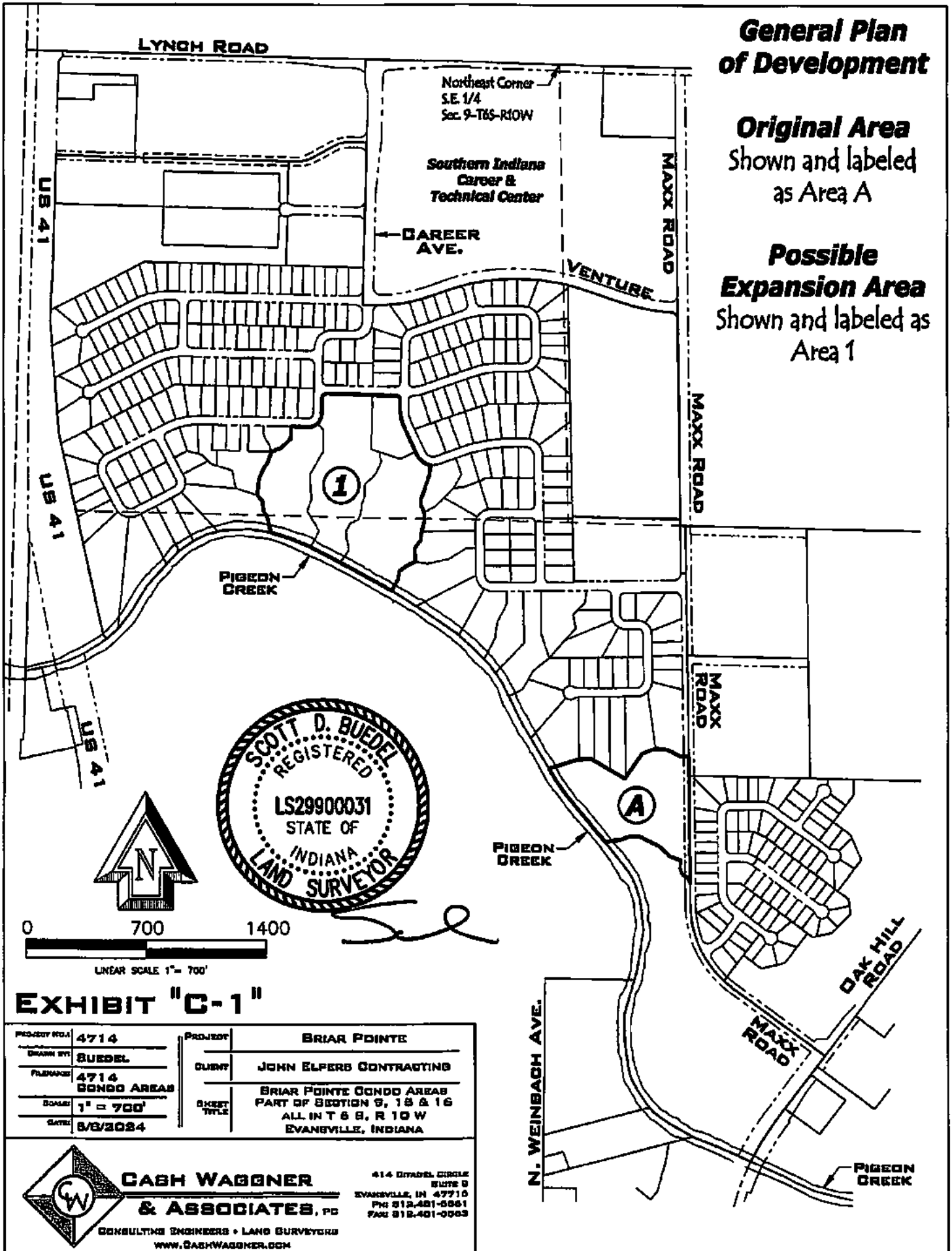

## EXHIBIT "C-1"

PROJECT NO.:	4714	PROJECT:	BRIAR POINTE
DRAWN BY:	BUEDEL	CLIENT:	JOHN ELPERB CONTRACTING
FILE NAME:	4714 CONDO AREAS	DISTRICT TITLE:	BRIAR POINTE CONDO AREAS PART OF SECTION 9, 18 & 16 ALL IN T 8 S, R 10 W EVANSVILLE, INDIANA
SCALE:	1" = 700'		
DATE:	8/8/2024		



**CASH WAGNER  
& ASSOCIATES, PC**

CONSULTING ENGINEERS • LAND SURVEYORS  
WWW.CASHWAGNER.COM

414 STADEL CIRCLE  
SUITE 8  
EVANSVILLE, IN 47710  
PH: 312-481-0561  
FAX: 312-481-0563



**EXHIBIT "C-2"**

**SITE PLAN**

SITING PLAN  
 1.000



<p><small>STATE OF TEXAS          DEPARTMENT OF TRANSPORTATION          TEXAS STATE ROAD DEPARTMENT          1000 WEST 11TH AVENUE          AUSTIN, TEXAS 78703</small></p>	 <p><i>David J. Cash</i>          ENGINEER</p>	 <p><b>CASH WAGNER          &amp; ASSOCIATES</b>  <small>ARCHITECTS, ENGINEERS, PLANNERS</small></p>	<p><small>PROJECT NO. 1000          SHEET NO. C-101          DATE 1.0.04.03</small></p>	<p><small>SCALE: AS SHOWN          1" = 100'</small></p>	<p><b>State Parks Lottery Center</b>          2700 Plaza Road          Fort Worth, Texas 76104</p> <p><b>SITE PLAN</b></p>	<p><small>DATE          1.0.04.03</small></p> <p><b>C-101</b></p>
---	---	---	---	--	--	---

**EXHIBIT "C-3"**

**FLOOR PLANS AND ELEVATIONS FOR DUPLEX CONDOMINIUM UNITS**

**(3BR left/2BR right)**

**Units 2011-1, 2011-2, 2025-1, 2025-2, 2037-1, 2037-2, 2704-1, 2704-2, 2726-1,  
and 2726-2**

071919

JOHN REEDS HOME BLDG 2  
21 NE. AVENUE RD.  
(WAVESIDE SH 477)

05-07-24

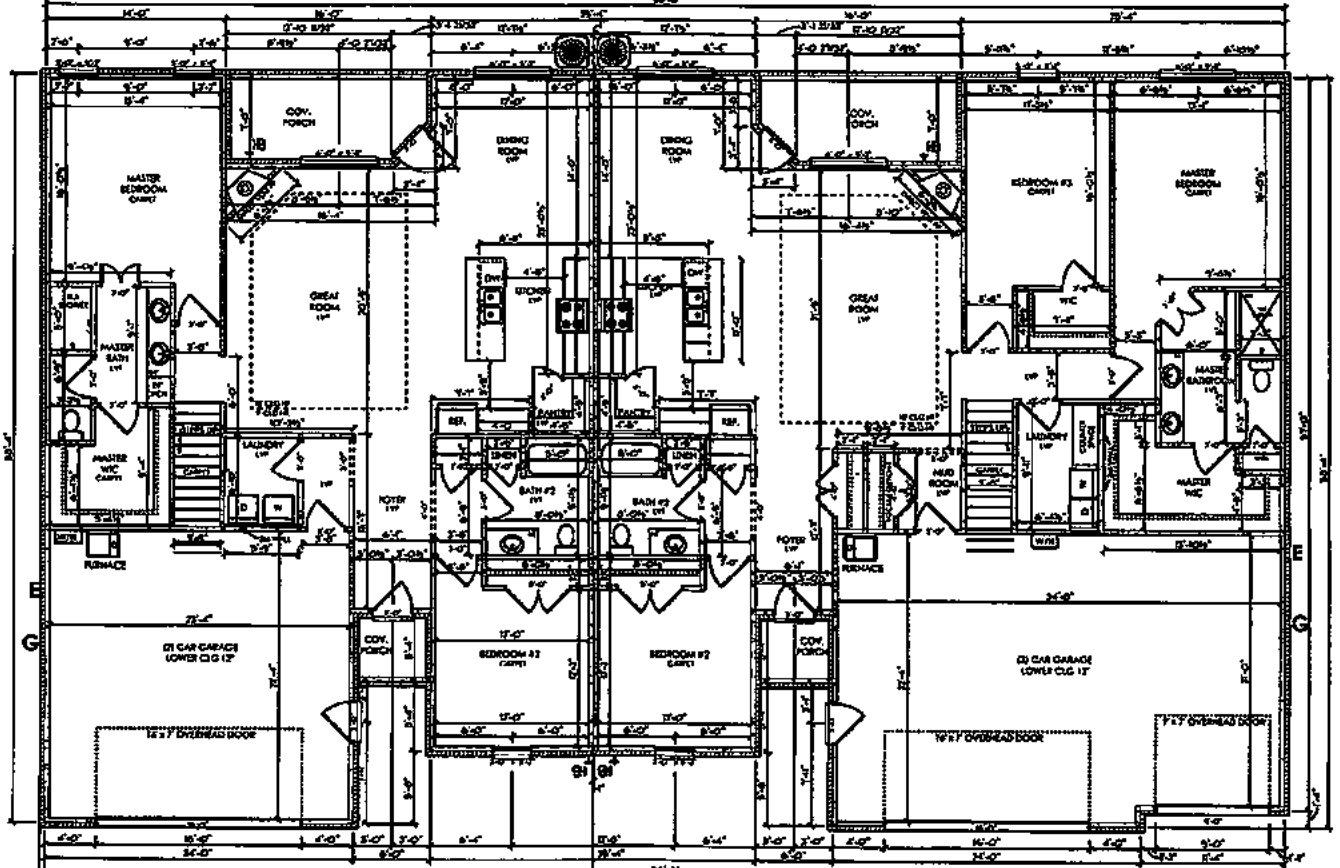

**FLOOR PLAN**

SCALE 1" = 3/8"

**CONDO PROJECT**

**2 BED W/ BONUS**

NOTE: F.C.L.G. H. UNLESS NOTED OTHERWISE

**SQFT.**

MAIN LEVEL	820
BONUS ROOM	203
TOTAL FINISHED	1023
GARAGE	343
FRONT PORCH	29
BACK PORCH	104

**CONDO PROJECT**

**3 BED W/ BONUS**

NOTE: F.C.L.G. H. UNLESS NOTED OTHERWISE

**SQFT.**

MAIN LEVEL	2114
BONUS ROOM	273
TOTAL FINISHED	2387
GARAGE	826
FRONT PORCH	79
BACK PORCH	124

071919

JOHN CLIPPER HOMES INC.  
28 W. ADLEY RD.  
EVANSVILLE IN 47711

05-07-24

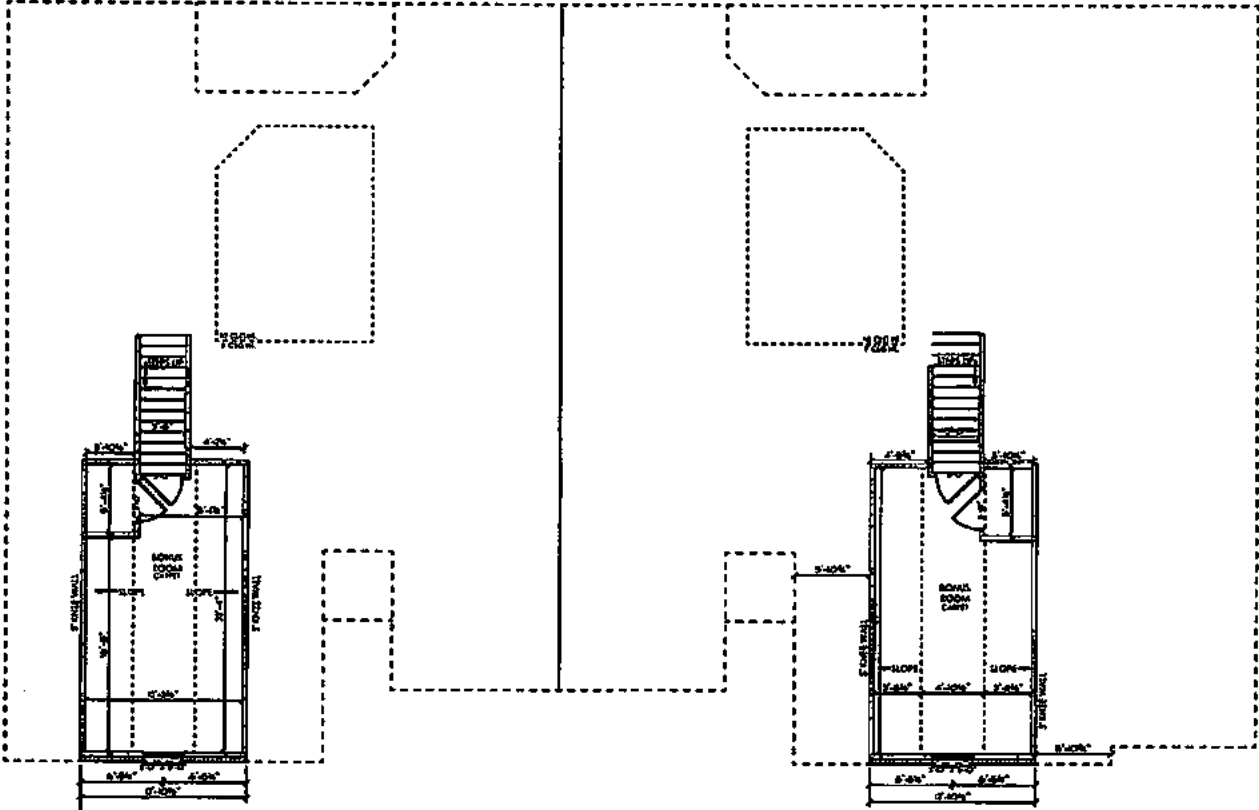

**BONUS PLAN**

**CONDO PROJECT**

**SQFT.**

**CONDO PROJECT**

**SQFT.**

SCALE 1" = 3/8"

**2 BED W/ BONUS**  
NOTE: IF CLS HL. SPACES NOTED OTHERWISE

MAIN LEVEL	1700
BONUS ROOM	200
TOTAL FRESH	2000
GARAGE	543
FRONT PORCH	29
BACK PORCH	84

**3 BED W/ BONUS**  
NOTE: IF CLS W/ UNLESS NOTED OTHERWISE

MAIN LEVEL	2114
BONUS ROOM	200
TOTAL FRESH	2314
GARAGE	529
FRONT PORCH	29
BACK PORCH	106

071919

JOHN ELPER ARCHITECTS  
3140 S. ASHLEY RD.  
EVANSTON, IL 60201

05-07-24

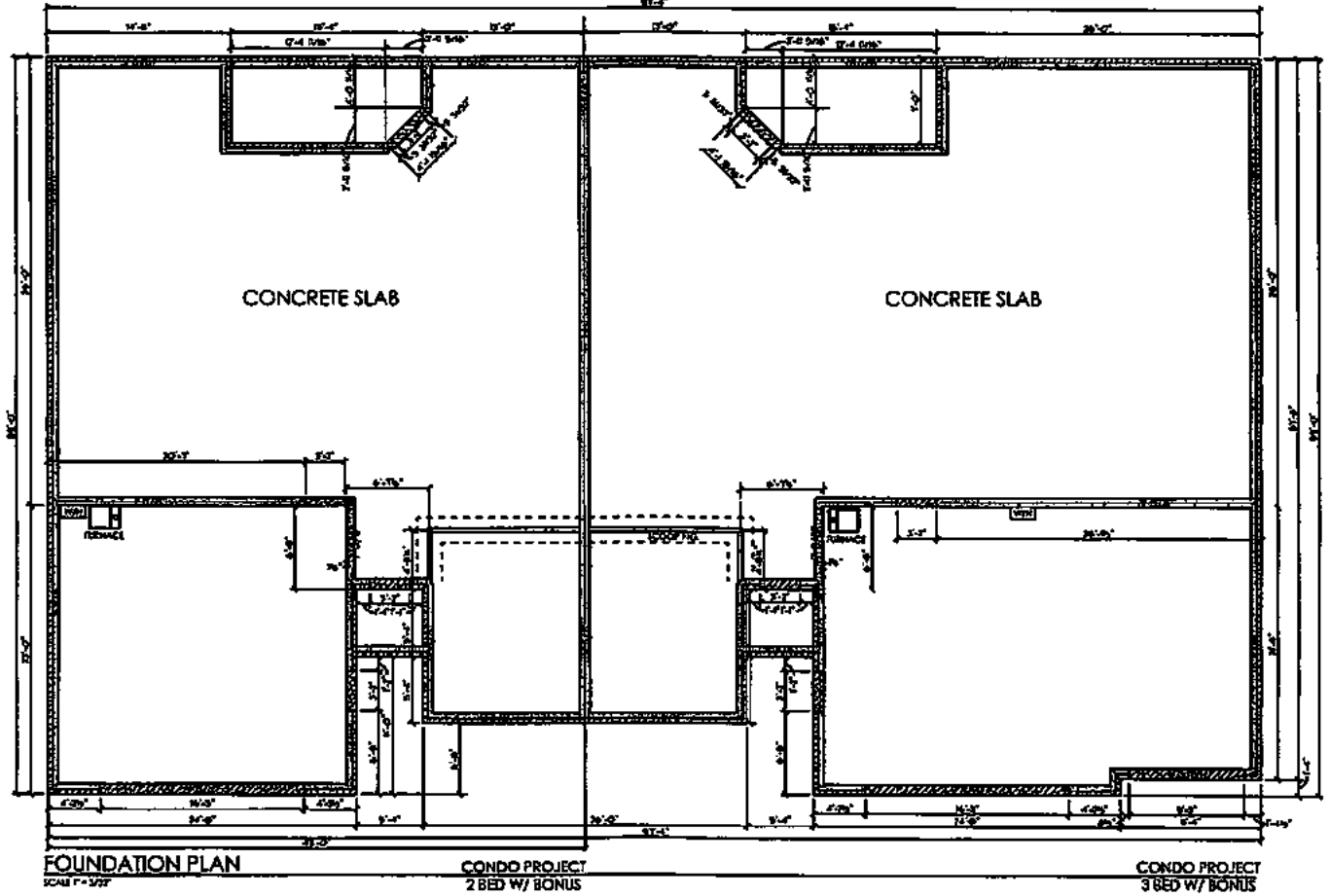

071919

JOHN LUMBER COMPANY  
1000 ALBERT RD.  
TAMMARA, IN 47470

05-07-24

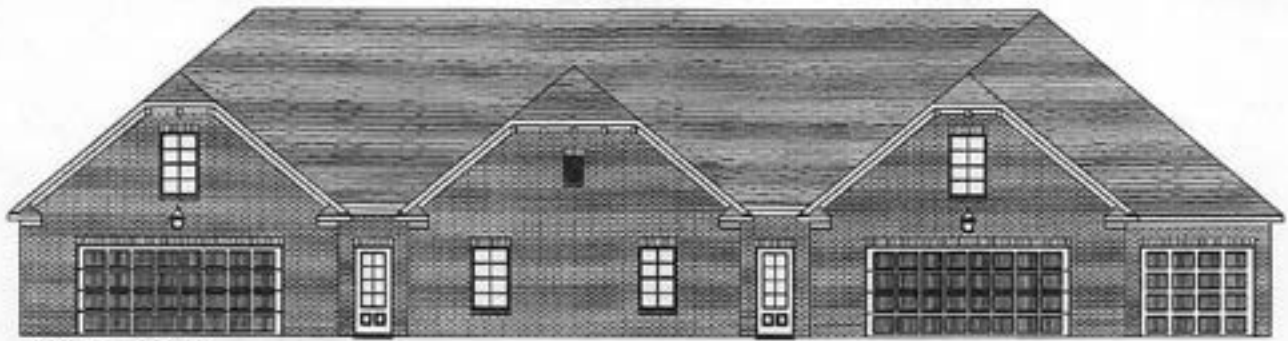

FRONT ELEVATION

SCALE 1" = 8'-0"

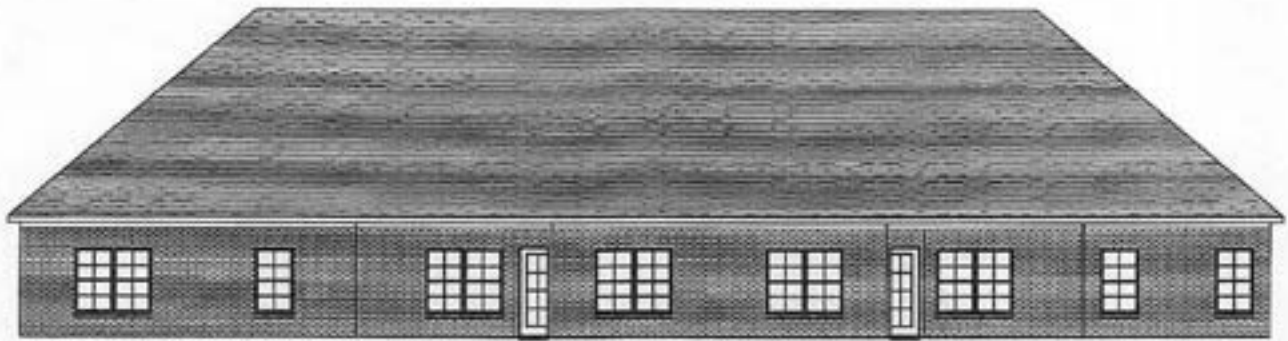

REAR ELEVATION

071919

JOHN GLENN HOMEWORKS  
30 W. ADAMS ST.  
CHICAGO, IL 60601

05-07-24

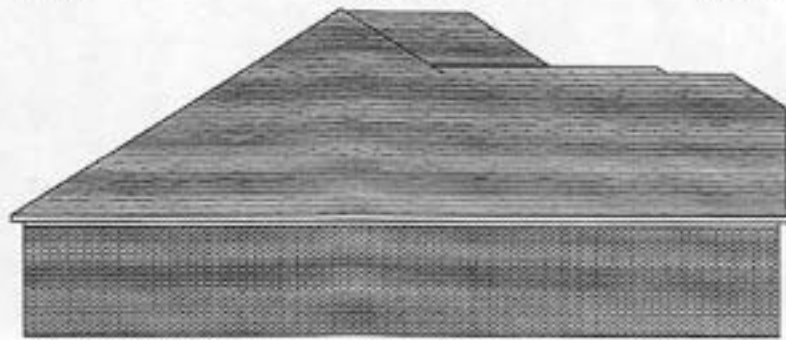

LEFT ELEVATION

SCALE 1/4" = 1'-0"

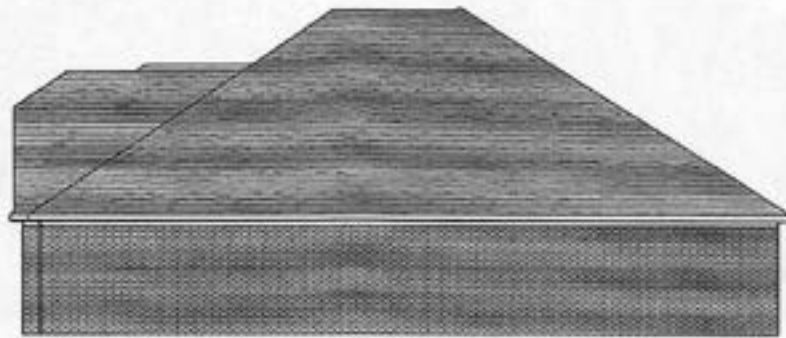

RIGHT ELEVATION

SCALE 1/4" = 1'-0"



071919

JOHN SUPER HOMES/0681  
21 1/2 ASHLEY RD.  
EVANSVILLE, IN 47711

05-07-24

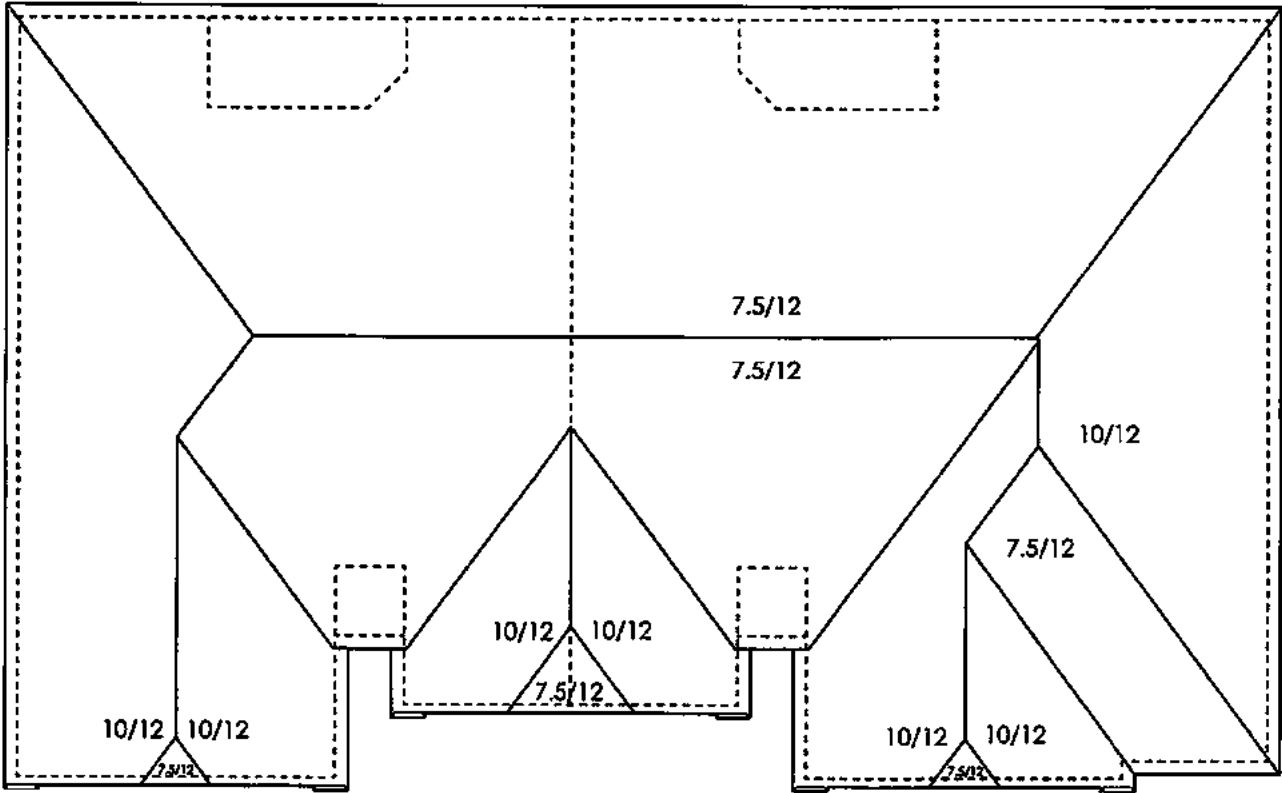

ROOF PLAN  
SHEET 1 OF 2

CONDO PROJECT  
2 BED W/ BONUS

CONDO PROJECT  
3 BED W/ BONUS

**EXHIBIT "C-4"**

**FLOOR PLANS AND ELEVATIONS FOR DUPLEX CONDOMINIUM UNITS**

**(2BR left/3BR right)**

**Units 2044-1, 2044-2, 2049-1, and 2049-2**

071919

JOHN EPPER HOMES/CONDO'S  
 2141 ASHBY RD.  
 EVANSVILLE, IN 47711  
 812-426-1111

10-25-21

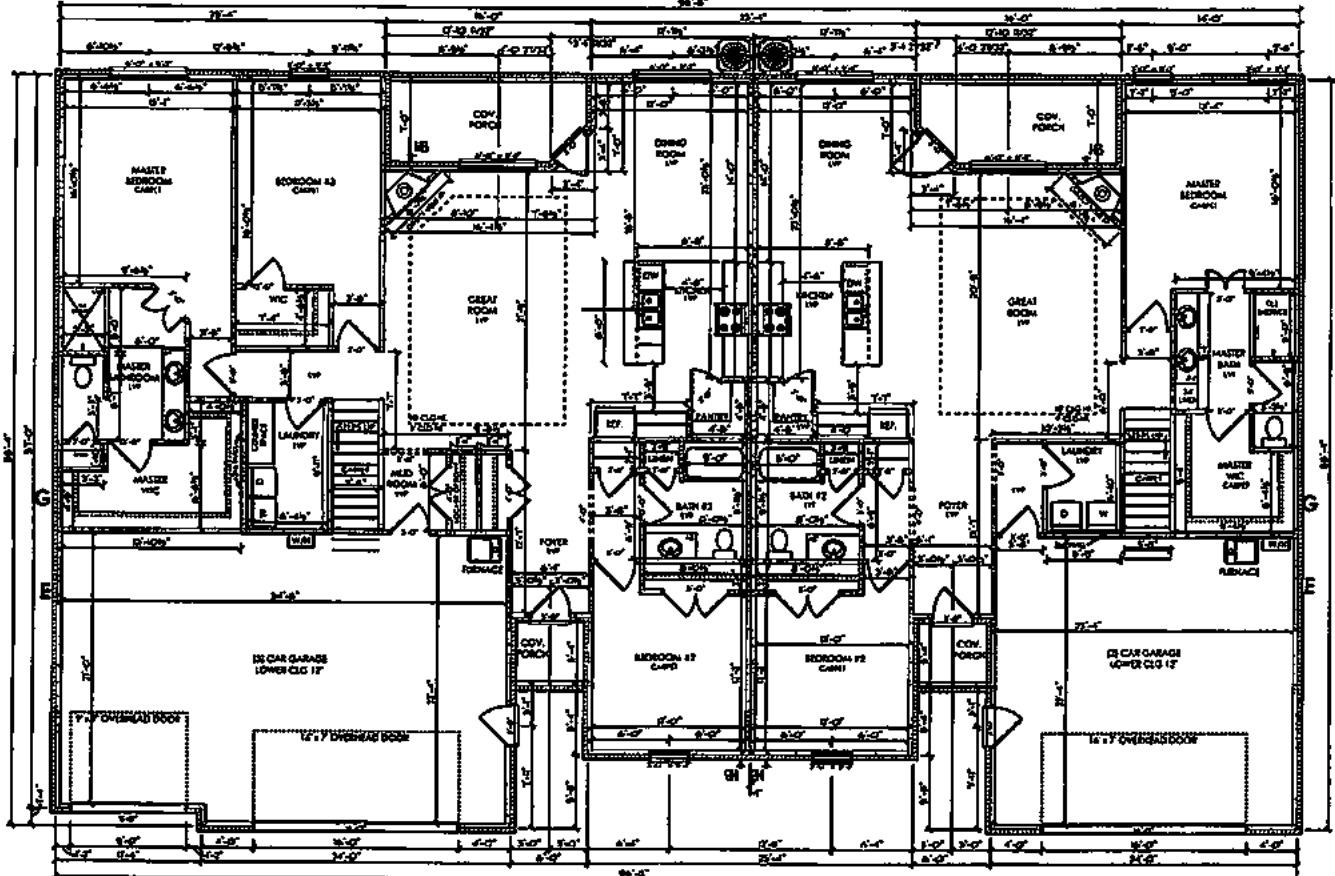

**FLOOR PLAN**  
 SCALE 1" = 3'-0"

**CONDO PROJECT**  
**3 BED W/ BONUS**  
 MORE 9' CLG HL UNLESS NOTED OTHERWISE

**SQFT.**  
 MAIN LEVEL 2114  
 BONUS ROOM 200  
 TOTAL FINISHED 2314  
 GARAGE 828  
 FRONT PORCH 27  
 BACK PORCH 164

**CONDO PROJECT**  
**2 BED W/ BONUS**  
 MORE 9' CLG HL UNLESS NOTED OTHERWISE

**SQFT.**  
 MAIN LEVEL 1700  
 BONUS ROOM 200  
 TOTAL FINISHED 1900  
 GARAGE 563  
 FRONT PORCH 27  
 BACK PORCH 124

071919

JOHN C. PERI HOME DESIGN 3  
31 MIL ADRIAN RD.  
EVANSTON, IL 60121

10-25-21

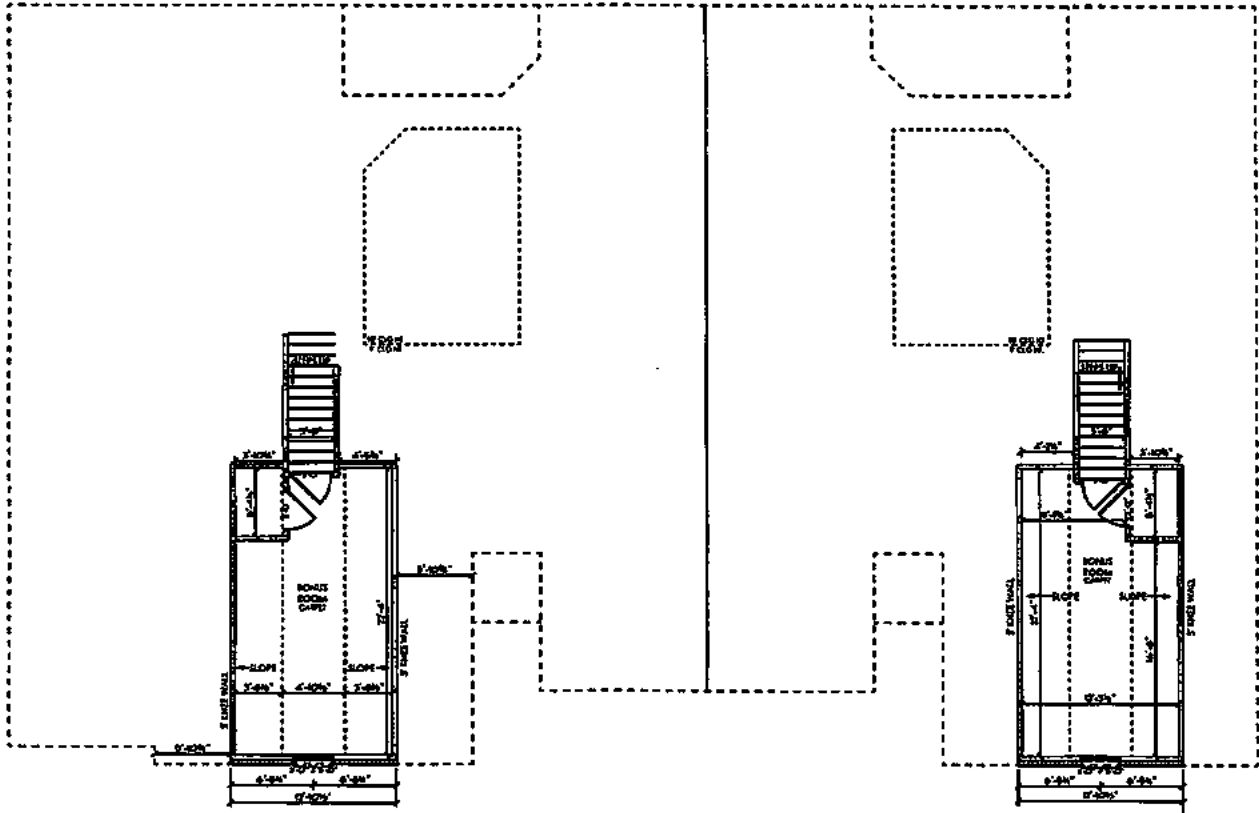

**BONUS PLAN**

SCALE 1/4" = 1'-0"

**CONDO PROJECT**

**3 BED W/ BONUS**

NOTE: IF CLO. HT. UNLESS NOTED OTHERWISE

**SQFT.**

MAIN LEVEL	214
BONUS ROOM	30
TOTAL FLOOR	244
GARAGE	98
FRONT PORCH	17
BACK PORCH	10

**CONDO PROJECT**

**2 BED W/ BONUS**

NOTE: IF CLO. HT. UNLESS NOTED OTHERWISE

**SQFT.**

MAIN LEVEL	178
BONUS ROOM	30
TOTAL FLOOR	208
GARAGE	98
FRONT PORCH	17
BACK PORCH	10

071919

CONDO PROJECT  
3 BED W/ BONUS

10-25-21

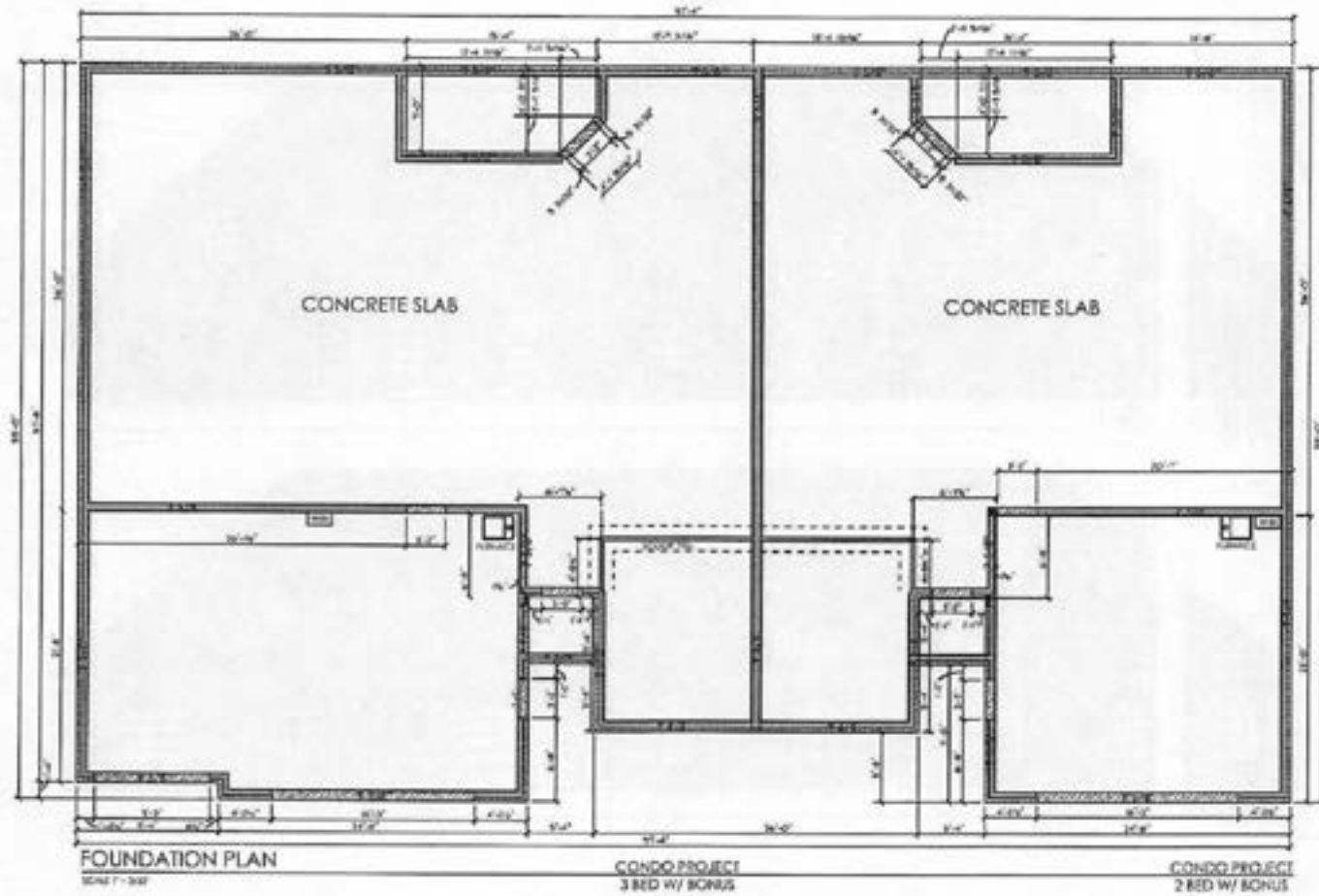

FOUNDATION PLAN

CONDO PROJECT  
3 BED W/ BONUS

CONDO PROJECT  
2 BED W/ BONUS

071919

JOHN F. PYLE ARCHITECTS  
2000 W. 10TH ST.  
SPRINGFIELD, IL 62761

10-25-21

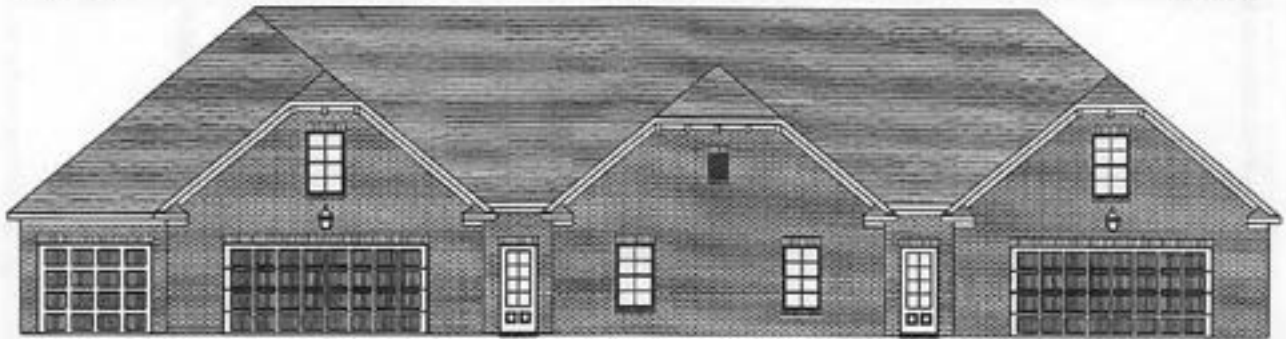

FRONT ELEVATION  
SCALE: 1/8"=1'-0"

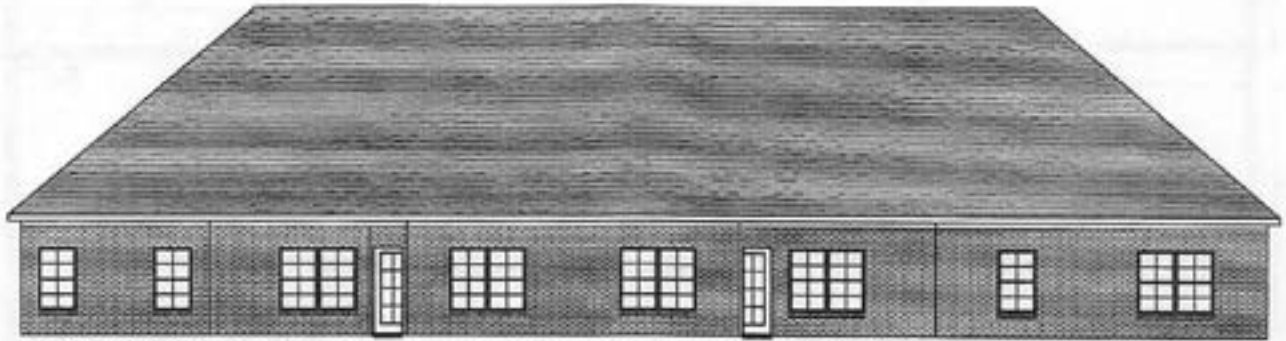

REAR ELEVATION

071919

JOHN EPPS FOUNDRY  
21 W. ASHLIN BLVD.  
BIRMINGHAM, AL 35211

09-24-19

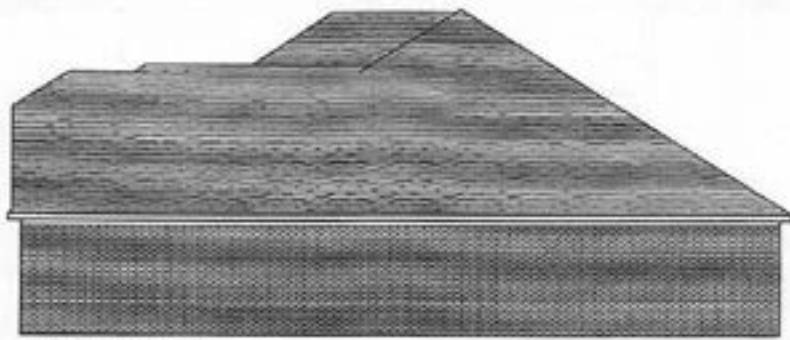

RIGHT ELEVATION

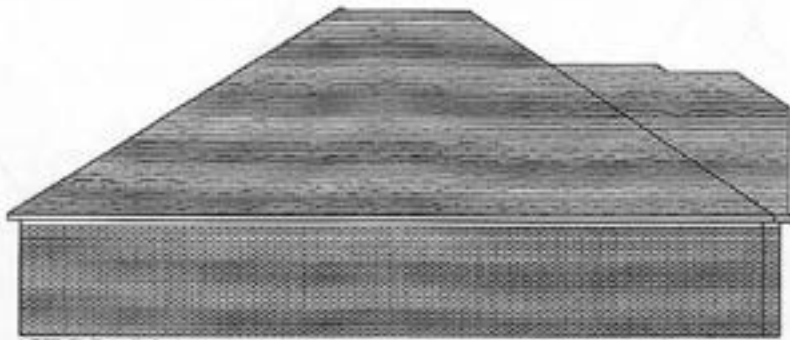

LEFT ELEVATION

ROOF PLAN

SCALE 1" = 8'-0"

CONDO PROJECT

3 BED W/ BONUS

CONDO PROJECT

2 BED W/ BONUS

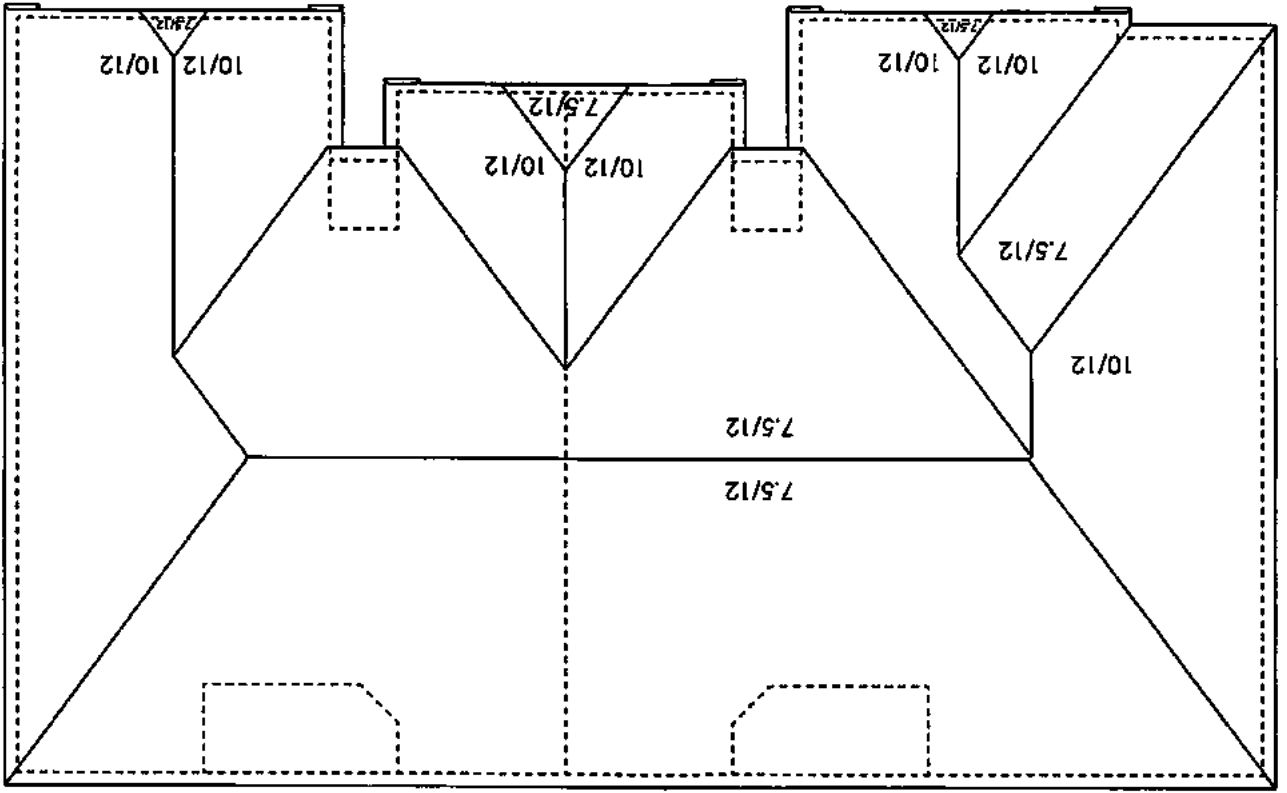

071919

APPROVED FOR CONSTRUCTION  
DATE: 09/24/19  
DRAWN BY: DTT

09-24-19



**EXHIBIT "C-5"**

**FLOOR PLANS AND ELEVATIONS FOR STAND ALONE CONDOMINIUM UNITS**

**Units 2003 and 2727**

071919

JOHN ELPERS HOMES/GEN 3  
21 MT. ASHLEY RD.  
EVANSVILLE, IN 47711

09-24-19

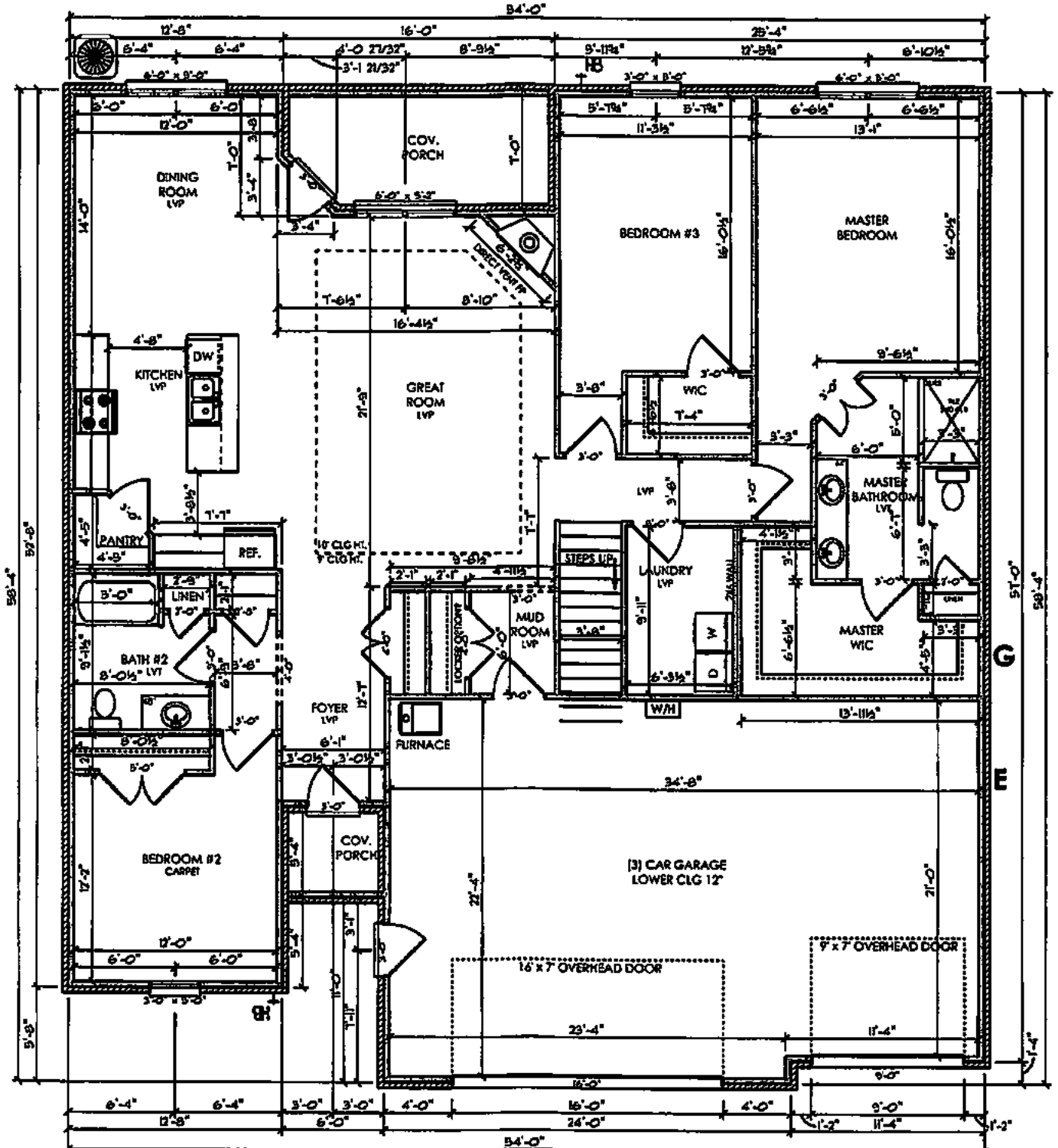

**FLOOR PLAN**

SCALE 1" = 1/8"

**CONDO PROJECT**

**3 BED W/ BONUS**

NOTE: 9' CLG HT. UNLESS NOTED OTHERWISE

**SQFT.**

MAIN LEVEL	2116
BONUS ROOM	300
TOTAL FINISHED	2416
GARAGE	808
FRONT PORCH	29
BACK PORCH	104

071919

JOHN ELPERS HOMES/GEN 3  
21 MT. ASHLEY RD.  
EVANSVILLE, IN 47711

09-24-19

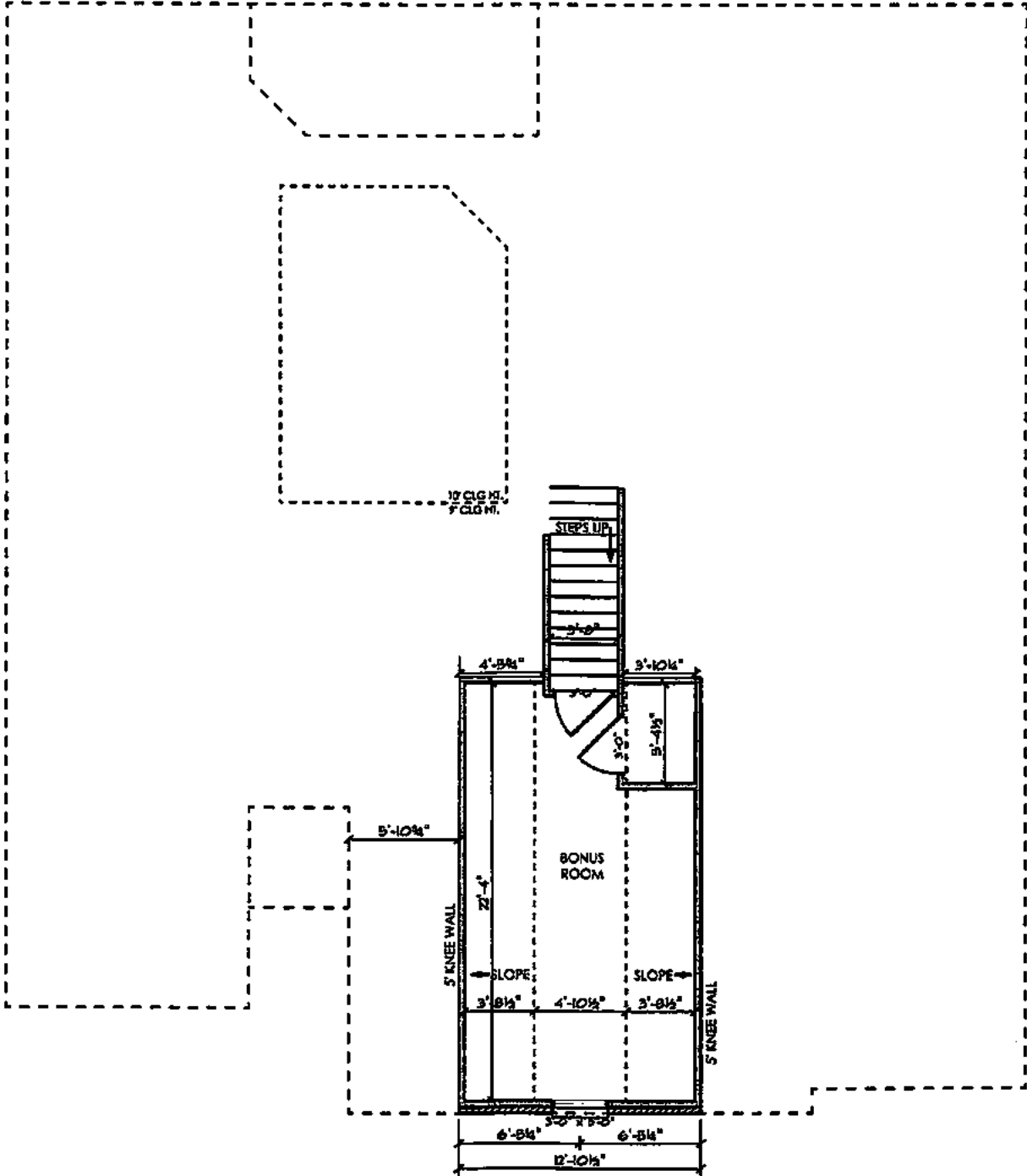

**BONUS PLAN**

SCALE 1" = 1/8"

**CONDO PROJECT**

**3 BED W/ BONUS**

NOTE: 8' CLG HT. UNLESS NOTED OTHERWISE

**SQFT.**

MAIN LEVEL	2116
BONUS ROOM	300
TOTAL FINISHED	2416
GARAGE	808
FRONT PORCH	29
BACK PORCH	104

071919

JOHN ELPERS HOMES/GEN 3  
21 MT. ASHLEY RD.  
EVANSVILLE, IN 47711

09-24-19

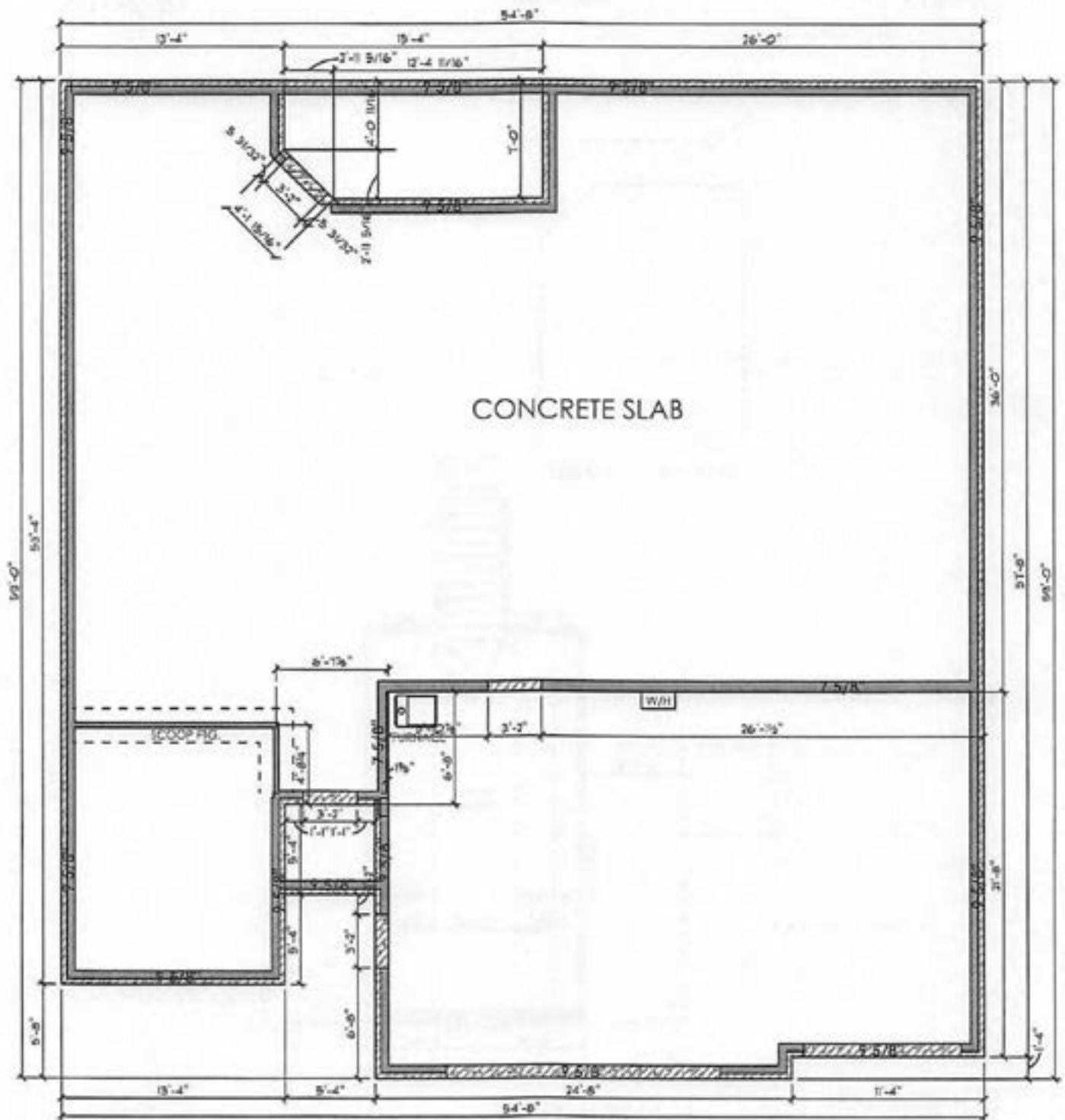

FOUNDATION PLAN

SCALE 1" = 1/8"

CONDO PROJECT  
3 BED W/ BONUS

071919

JOHN ELPERS HOMES/GEN 3  
21 MI. ASHLEY RD.  
EVANSVILLE, IN 47711

09-24-19



FRONT ELEVATION

SCALE 1" = 1/8"

CONDO PROJECT  
3 BED W/ BONUS



REAR ELEVATION

SCALE 1" = 1/8"

CONDO PROJECT  
3 BED W/ BONUS

071919

JOHN ELPERS HOMES/GEN 3  
21 MT. ASHLEY RD.  
EVANSVILLE, IN 47711

09-24-19

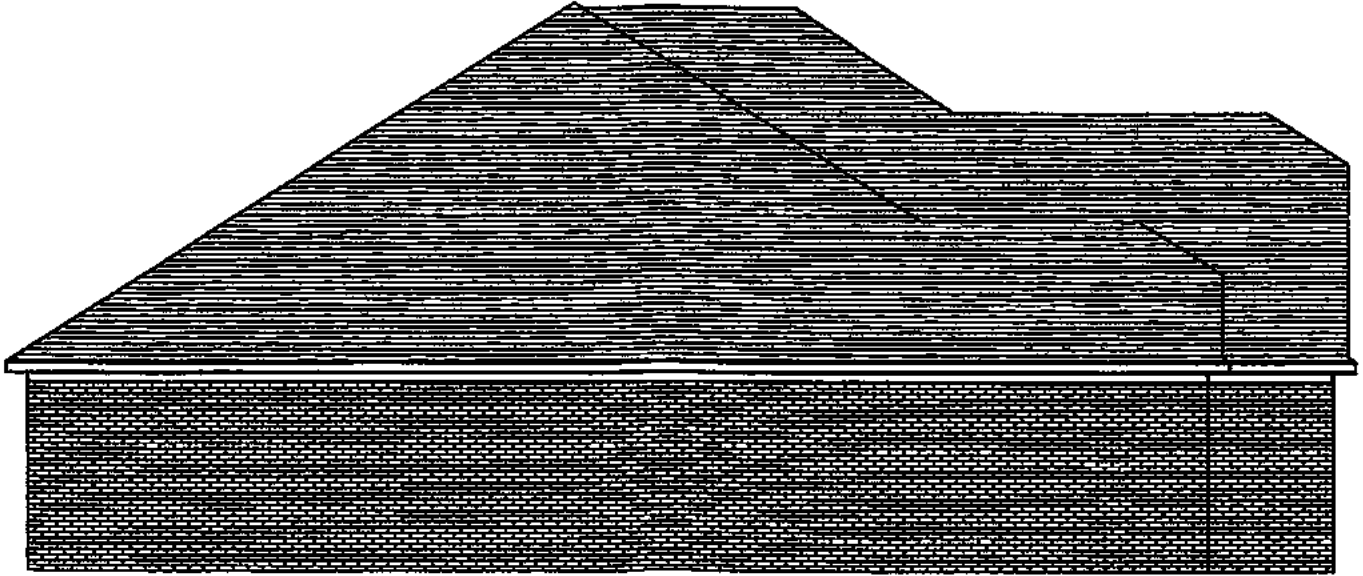

LEFT ELEVATION

SCALE 1" = 1/8"

CONDO PROJECT  
3 BED W/ BONUS

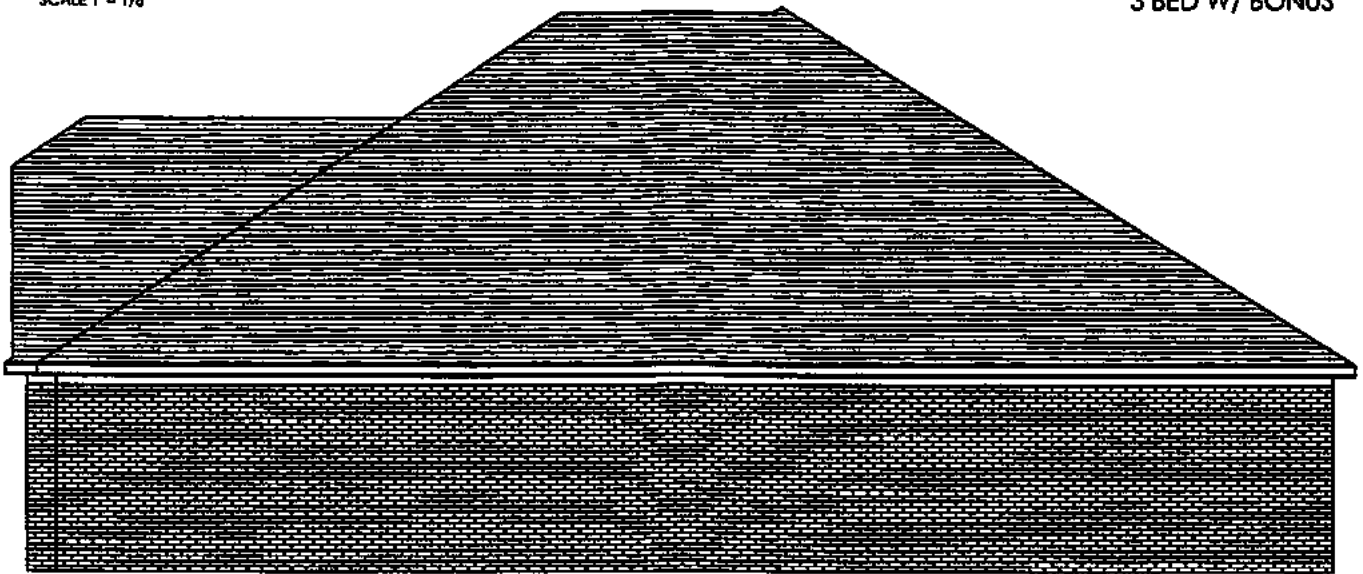

RIGHT ELEVATION

SCALE 1" = 1/8"

CONDO PROJECT  
3 BED W/ BONUS

071919

JOHN ELPERS HOMES/GEN 3  
21 MT. ASHLEY RD.  
EVANSVILLE, IN 47711

09-24-19

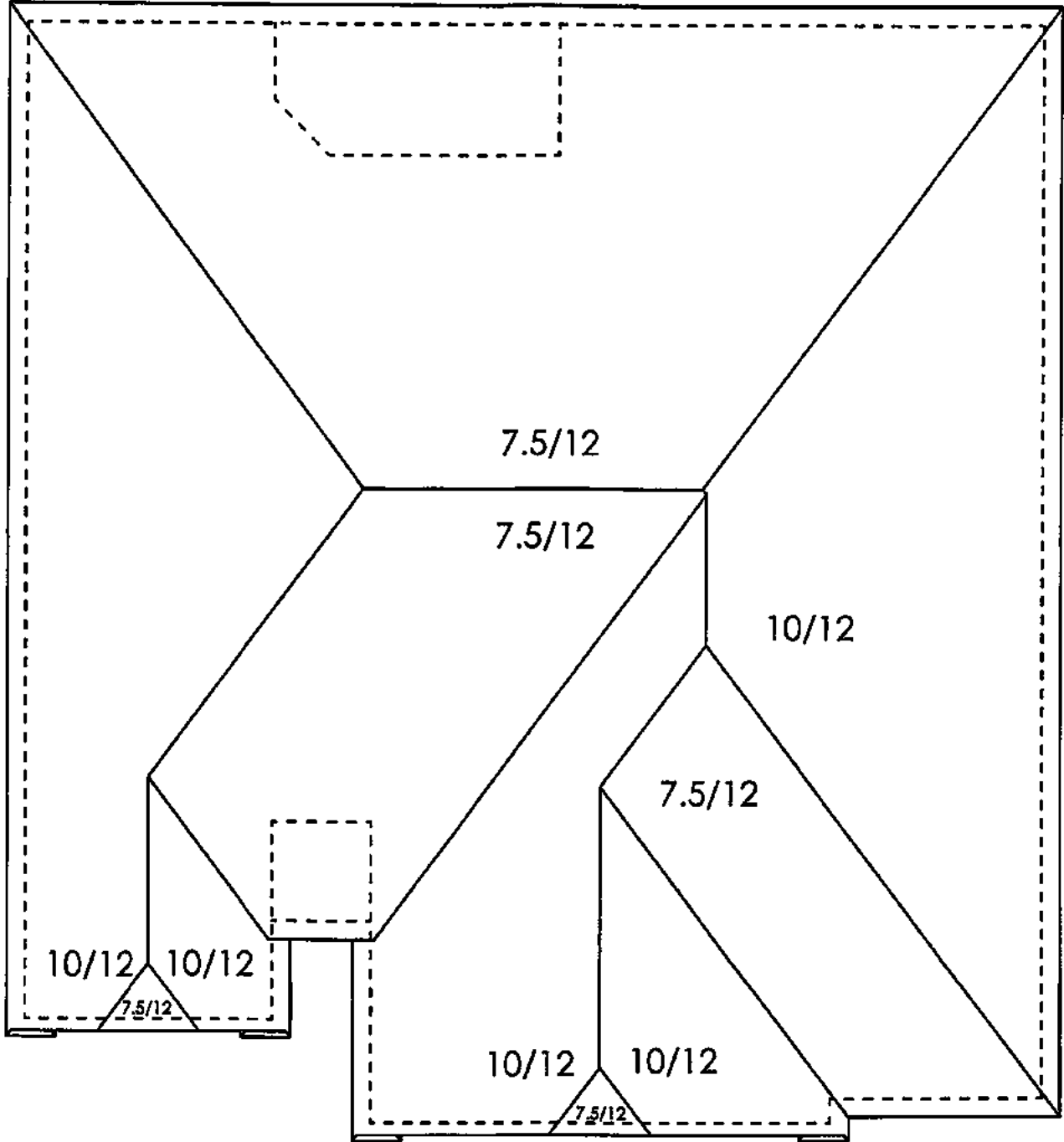

ROOF PLAN

SCALE 1" = 1/8"

CONDO PROJECT  
3 BED W/ BONUS

**EXHIBIT "D"**

**BYLAWS OF BRIAR POINTE ESTATES CONDOMINIUM ASSOCIATION**



## **CODE OF BY-LAWS**

### **OF**

## **BRIAR POINTE ESTATES CONDOMINIUMS OWNERS ASSOCIATION, INC.**

### **ARTICLE I**

#### **Identification and Applicability**

**Section 1.01. Identification and Adoption.** These By-Laws are adopted simultaneously with the execution of a certain Declaration creating Briar Pointe Estates Condominiums to which these By-Laws are attached and made a part. The Declaration is incorporated herein by reference, and all of the covenants, rights, restrictions and liabilities therein contained shall apply to and govern the interpretation of these By-Laws. Except as otherwise provided in Section 1.02 hereof, the definitions and terms as defined and used in the Declaration shall have the same meaning in these By-Laws and reference is specifically made to Paragraph 1 of the Declaration containing definitions of terms. The provisions of these By-Laws shall apply to the Property and the administration and conduct of the affairs of the Association.

**Section 1.02. Additional Definitions.** Notwithstanding any other definition in the Declaration, the following terms as used in these By-Laws shall have the following meanings:

- a. "Articles" means the Articles of Incorporation of the Association.
- b. "Assessment" means all sums lawfully assessed against the Owners or as declared or authorized by the Act, the Declaration, any Supplementary Declaration, the Articles, or these By-Laws.
- c. "Directors" means all the members of the Board of Directors including the Initial Board of Directors and "Director" means any individual member thereof.
- d. "Managing Agent" means a reputable and recognized professional property management agent employed by the Board pursuant to Section 3.06.
- e. "Member" means a member of the Association and "Members" means more than one member of the Association.
- f. "Regular Assessment" means the Assessment levied pursuant to Section 6.02.
- g. "Special Assessment" means the Assessment levied pursuant to Section 6.03.
- h. "Statute" means the Indiana Nonprofit Corporation Act of 1991, as amended.

**Section 1.03. Individual Application.** All of the Owners, future Owners, tenants, future tenants, or their guests and invitees, or any other person that might use or occupy a Condominium Unit or

any part of the Property, shall be subject to the restrictions, terms and conditions set forth in the Declaration, the Articles, these By-Laws and the Act, and to any rules and regulations adopted by the Board as herein provided.

## **ARTICLE II**

### **Meetings of Association**

**Section 2.01. Purpose of Meetings.** After the Applicable Date, at least annually, and at such other times as may be necessary, the meetings of the Owners shall be held for the purpose of electing the Board (subject to the provisions of Section 3.02 hereof), approving the annual budget, providing for the collection of Common Expenses and for such other purposes as may be required by the Declaration, the Articles, these By-Laws, the Act or the Statute. Meetings shall not be required prior to the Applicable Date during the period of time the Initial Board of Directors shall be engaged in the performance of the obligations of the Association as herein provided.

**Section 2.02. Annual Meetings.** The annual meeting of the Members shall be held on a date established by the Board pursuant to notice provided in accordance with these By-Laws within six (6) months of the close of each fiscal year of the Association. At the annual meeting, the Owners shall (subject to the provisions of Section 3.02 hereof) elect the Board of Directors in accordance with the provisions of these By-Laws and transact such other business as may properly come before the meeting.

**Section 2.03. Special Meetings.** A special meeting of the Members may be called by resolution of the Board or upon a written petition of Owners who have not less than thirty percent (30%) of the Percentage Vote. The resolution or petition shall be presented to the President or Secretary of the Association (references herein to an officer shall be to that officer of the Association) and shall state the purpose for which the meeting is to be called. No business shall be transacted at a special meeting except as stated in the petition or resolution.

**Section 2.04. Notice and Place of Meeting.** Except with respect to the Initial Board, all meetings of the Members shall be held at any suitable place in Vanderburgh County, Indiana, as may be designated by the Board. Written notice stating the date, time and place of any meeting and, in the case of a Special Meeting, the purpose or purposes for which the meeting is called, shall be delivered or mailed by the Secretary to each Member entitled to vote thereon not less than ten (10) days prior to the date of such meeting. If mailed, the notice shall be mailed or delivered to the Owners at the addresses of their respective Condominium Units and not otherwise. A copy of each such written notice shall also be delivered or mailed simultaneously by the Secretary to each Mortgagee (a) who requests in writing that such notices be delivered to it, and (b) who has furnished the Association with its name and address in accordance with these By-Laws. Attendance at any meeting in person by agent or by proxy shall constitute a waiver of notice of such meeting.

#### **Section 2.05. Voting.**

- a. **Number of Votes.** All Persons who own a Condominium Unit shall jointly (and not severally) be entitled to cast one vote for each Condominium Unit they own on each matter

coming before the meeting as to which they are entitled to vote.

- b. **Multiple Owners.** Where the Owner of a Condominium Unit constitutes or consists of more than one Person, or is a partnership, there shall be only one voting representative entitled to all of the Percentage Vote allocable to that Condominium Unit. At the time of acquisition of title to a Condominium Unit by a multiple Owner or a partnership, those Persons constituting such Owner or the partners shall file with the Secretary an irrevocable proxy appointing one of such Persons or partners as the voting representative for such Condominium Unit, which shall remain in effect until all of those Persons constituting such multiple Owner or a majority of the partners in such partnership designate another voting representative or the representative previously appointed relinquishes such appointment in writing, becomes incompetent, dies or such appointment is otherwise rescinded by order of a court of competent jurisdiction or the Owner no longer owns such Condominium Unit. Such appointed voting representative may grant a proxy to another to vote in his place at a particular meeting or meetings pursuant to paragraph (a) of this Section 2.05, which shall not constitute a permanent relinquishment of his right to act as voting representative for the Condominium Unit.
- c. **Voting by Corporation or Trust.** Where a corporation or trust is an Owner or is otherwise entitled to vote, a trustee may cast the vote on behalf of the trust, and the agent or other representative of the corporation duly empowered by the board of directors of such corporation may cast the vote to which the corporation is entitled. The secretary of the corporation, or a trustee of the trust, so entitled to vote shall deliver or cause to be delivered prior to the commencement of the meeting a certificate signed by such person to the Secretary stating who is authorized to vote on behalf of said corporation or trust.
- d. **Proxy.** An Owner may vote either in person or by his duly authorized and designated attorney-in-fact. Where voting is by proxy, the owner shall duly designate his attorney-in-fact in writing, delivered to the Secretary prior to the commencement of the meeting.
- e. **Pledges.** If the vote of an Owner or Owners has been pledged by mortgage, security agreement, conditional assignment, or other instrument, an executed copy of which has been filed with the Secretary, only the pledgee shall be entitled to cast the vote of such Owner or Owners upon those matters which the Owner or Owners vote is so pledged.
- f. **Quorum.** Except in the Declaration, these By-Laws, the Act or the Statute, Twenty-five Percent (25%) of the Owners shall constitute a quorum at all meetings of the Members.

#### **Section 2.06. Conduct of Meetings.**

- a. **Annual Meeting.** The President shall act as the chairman of all annual meetings of the Association if present. At all annual meetings, the chairman shall call the meeting to order at the duly designed time and business will be conducted in the following order:
  - i. **Ascertainment of a Quorum.** For purposes of determining whether or not a quorum is present, the Secretary shall call the roll of Members or take such

other action as may be required to establish that a quorum is present.

- ii. **Reading of Minutes.** The Secretary shall read the minutes of the last annual meeting and the minutes of any special meeting held subsequent thereto unless such reading is waived by a Majority Vote.
  - iii. **Treasurer's Report.** The Treasurer shall report to the Owners concerning the financial condition of the Association and answer relevant questions of the Owners concerning the Common Expenses and financial report for the prior year and the proposed budget for the current year.
  - iv. **Budget.** After the Applicable Date, the proposed budget for the current fiscal year shall be presented to the Owners for approval or amendment.
  - v. **Election of Board of Directors.** After the Applicable Date, nominations for the Board may be made by any Owner from those Persons eligible to serve. Voting for the Board will be by paper ballot. Each Owner may cast the total number of votes to which he is entitled for as many nominees as are to be elected; however, he shall not be entitled to cumulate his votes. Those persons receiving the highest number of votes shall be elected. In the event of tie vote, a run- off election shall be held within ten (10) days after the tie vote, with the two (2) nominees that received the highest number of votes for a Directorship being the only nominee for such Directorship. Prior to the Applicable Date, the nomination and election of the Board shall be governed by the provisions of Section 3.02 hereof.
  - vi. **Other Business.** Other business may be brought before the meeting only by decision of the Board of Directors or upon a written request of an Owner submitted to the Secretary of the Association at least seven (7) days prior to the date of the meeting, except that such written request may be waived at the meeting if agreed by a Majority of Owners.
  - vii. **Adjournment.**
- b. **Special Meetings.** The President shall act as chairman of any special meetings of the Association, if present. The chairman shall call the meeting to order at the duly designated time and the only business to be considered at such meeting shall be the matters for which such meeting was called, as set forth in the notice of such special meeting.

### **ARTICLE III Board of Directors**

**Section 3.01. Management.** The affairs of the Association and Briar Pointe Estates Condominiums shall be governed and managed by the Board of Directors. Prior to the Applicable Date as defined in the Declaration, the Board shall be composed of three (3) individuals, or such

greater number as the Initial Board of Directors shall determine. After the Applicable Date, the Board shall be composed of not less than three (3) individuals. Except with respect to the Initial Board of Directors, no individual shall be eligible to serve as a Director unless such person is or is deemed in accordance with the Declaration to be, an Owner, including an individual appointed by Declarant (as defined in the Declaration) as provided in Section 3.02 hereof.

**Section 3.02. Initial Board of Directors.** The Initial Board of Directors shall consist of John J. Elpers, Jr., Annette Elpers, Brittani E. Frank and Jonathan J. Elpers, all of whom have been or shall be appointed by Declarant. Notwithstanding anything to the contrary contained in, or any other provisions of, these By-Laws, the Declaration, the Act or the Statute (a) the Initial Board shall hold office until the Applicable Date, and (b) in the event of any vacancy or vacancies occurring in the Initial Board for any reason or cause whatsoever, prior to the Applicable Date, every such vacancy shall be filled by the Declarant, who shall thereafter be deemed a member of the Initial Board.

Each Owner, by acceptance of a deed to a Condominium Unit or by acquisition of any interest in a Condominium Unit by any type of juridic acts, inter vivos or causa mortis, or otherwise, shall be deemed to have appointed Declarant as such Owner's agent, attorney-in-fact and proxy, which appointment shall be deemed to be coupled with an interest and irrevocable until the Applicable Date, to exercise all of said Owner's right to vote and to vote as Declarant determines on all matters as to which members are entitled to vote under the Declaration, these By-Laws, the Act, the Statute or otherwise. This Appointment of Declarant as such Owner's agent, attorney-in-fact and proxy shall not be affected by incompetence of the Owner granting the same

The Initial Board of Directors shall have the full power and authority to act for and on behalf of the Association, without limitation, without the election of officers for the Association and without meetings of the Owners or their prior consent in the discharge of the duties and responsibilities of the Association under the condominium documents. The Initial Board of Directors shall collect Assessments and pay Association expenses until the Applicable Date.

**Section 3.03. Term of Office and Vacancy.** Subject to the provisions of Section 3.02 hereof, the Board shall be elected at each annual meeting of the Association. Each Director shall hold office throughout the term of his election and until his successor is elected and qualified. Subject to the provisions of Section 3.02 hereof as to the Initial Board, any vacancy or vacancies occurring in the Board shall be filled by a vote of a majority of the remaining Directors or by vote of the Owners if a Director is removed in accordance with Section 3.04. The Director so filling a vacancy in accordance with the Members and shall serve until the next annual meeting or until his successor is elected and qualified. At the first annual meeting following any such vacancy, a Director shall be elected for the balance of the term of the Director so removed or in respect to whom there has otherwise been a vacancy.

**Section 3.04. Removal of Directors.** A Director or Directors, except the members of the Initial Board, may be removed with or without cause by a Majority of the Percentage Vote at a special meeting of the Members duly called and constituted for that purpose. In such case, successors shall be elected at the same meeting from eligible Owners nominated at the meeting. A Director so elected shall serve until the next annual meeting of the Members or until a successor is duly elected

and qualified.

**Section 3.05. Duties of the Board of Directors.** The Board shall provide for the administration of Briar Pointe Estates Condominiums, the maintenance, repair, upkeep and replacement of the Common Areas and Limited Common Areas (unless the same are otherwise the responsibility or duty of the Owners of Condominium Units pursuant to the Declaration, By-Laws or any other document constituting the operating documents of the Regime), and the collection and disbursement of the Common Expenses. The Initial Board of Directors shall discharge such duties until the Applicable Date, After the Applicable Date, the Board may, on behalf of the Association, employ a Managing Agent upon such terms as the Board shall find, in its discretion, reasonable and customary. The Managing Agent shall assist the Board in carrying out its duties, which include, but are not limited to:

- a. protection, surveillance and replacement of the Common Areas and Limited Common Areas, including, without limitation, the enforcement of the prohibition of vehicular parking in the right-of-way of streets and roads adjacent to the Property or in private roads constructed in connection with the Condominium, unless same are otherwise the responsibility or duty of the Owners of Condominium Units; provided, however, that this duty shall not include or be deemed or interpreted as a requirement that the Association, the Board or any Managing Agent must provide any on-site or roving guards, security service or security system for protection or surveillance, and the same need not be furnished;
- b. procuring of utilities used in connection with Briar Pointe Estates Condominiums including if necessary private utilities, removal of garbage and waste, and snow removal from the Common Areas;
- c. landscaping, painting, decorating, furnishing, maintaining and repairing the Common Areas, and, where applicable the Limited Common Areas;
- d. surfacing, paving and maintaining parking areas and sidewalks as well as any private streets;
- e. washing and cleaning of exterior window surfaces of the Condominium Units;
- f. assessment and collection from the Owners of the Owner's share of the Common Expenses;
- g. preparation of the proposed annual budget;
- h. preparing and delivering annually to the Owners a full accounting of all receipts and expenses in the prior year;
- i. keeping a current, accurate and detailed record of receipts and expenditures affecting the Property, specifying and itemizing the Common Expenses;
- j. procuring and maintaining for the benefit of the Owners, the Association and the Board the

insurance coverages required by Section 8.01 and such other insurance coverages as the Board, in its sole discretion, may deem necessary or advisable;

- k. making available to Owners and Mortgagees current copies of Declaration, By-Laws and rules and regulations governing Briar Pointe Estates Condominiums ("Organizational Documents") and any other books, records and financial statements of the Association. The Board shall also make available to prospective purchasers of Condominium Units current copies of the Organizational Documents and the most recent annual audited financial statement if such statement has been prepared.

**Section 3.06. Powers of the Board of Directors.** The Board shall have such powers as are reasonable and necessary to accomplish the performance of their duties. Such powers are exclusively reserved to the Initial Board of Directors until the Applicable Date. These powers include, but are not limited to, the power:

- a. to employ a Managing Agent to assist the Board in performing its duties and to retain or release a Managing Agent after the Applicable Date who may have been selected by the Initial Board;
- b. to purchase for the benefit of the Owners such equipment, materials, labor and services as may be necessary in the judgment of the Board;
- c. to employ legal counsel, architects, contractors, accountants and others as in the judgment of the Board may be necessary or desirable in connection with the business and affairs of Briar Pointe Estates Condominiums;
- d. to employ, designate, discharge and remove such personnel as in the judgment of the Board may be necessary for the maintenance, upkeep, repair and replacement of the Common Areas and, where applicable, the Limited Common Areas;
- e. to include the costs of all of the above and foregoing as Common Expenses and to pay all of such costs therefrom;
- f. to open and maintain a bank account or accounts in the same name of the Association; and
- g. to adopt, revise, amend and alter from time to time rules and regulations with respect to use, occupancy, operation and enjoyment of the Property.

**Section 3.07. Limitation on Board Action.** After the Applicable Date, the authority of the Board to enter into contracts shall be limited to contracts involving a total expenditure of less than Five Thousand Dollars (\$5000.00) without obtaining the prior approval of a Majority of Owners, except that in the following cases such approval shall not be necessary:

- a. contracts for replacing or restoring portions of the Common Areas or Limited Common Areas damaged or destroyed by fire or other cause where the cost thereof is payable out of insurance proceeds actually received;

- b. proposed contracts and proposed expenditures expressly set forth in the proposed annual budget as approved by the Owners at the annual meeting; and
- c. expenditures necessary to deal with emergency conditions in which the Board reasonably believes there is insufficient time to call a meeting of the Owners.

**Section 3.08. Compensation.** No Director shall receive any compensation for his services as a Director except to such extent as may be expressly authorized by a Majority of the Percentage Vote. The Initial Board of Directors shall serve without compensation other than that which may be provided by the Declarant. The Managing Agent shall be entitled to reasonable compensation for its services, the cost of which shall be a Common Expense.

**Section 3.09. Meetings.**

- a. **Organization Meeting.** After the Applicable Date, the Board shall meet each year within ten (10) days following the date of the annual meeting of the Association, at such time and place as shall be fixed at the annual meeting, for the purpose of organization, election of officers and consideration of any other business that may properly be brought before the meeting, and no notice shall be necessary to any newly elected Directors in order legally to constitute such meeting if a quorum is present.
- b. **Regular Meetings.** Regular meetings of the Board may be held at such time and place as shall be determined from time to time by a majority of the Directors. The Secretary shall give notice of regular meeting of the Board to each Director personally or by United States mail at least five (5) days prior to the date of such meeting.
- c. **Special Meetings.** Special meetings may be called by the President or any two (2) members of the Board. The Director or Directors calling such meeting shall give written notice thereof to the Secretary who shall either personally or by mail, and at least three (3) days prior to the date of such meeting, give notice to the members of the Board. The notice of the meeting shall contain a statement of the purpose for which the meeting is called. Except with respect to the Initial Board, such meeting shall be held at such place and at such time within Vanderburgh County, Indiana, as shall be designated in the notice.

**Section 3.10. Waiver of Notice.** Before any meeting of the Board, any Director may, in writing, waive notice of such meeting and such waiver shall be deemed equivalent to the giving of such notice. The presence of any Director at a meeting or his subsequent consent to the actions taken there at, shall, as to such Director, constitute a waiver of notice of the time, place and purpose thereof. If all Directors are present at any meeting of the Board, no notice shall be required and any business may be transacted at such meeting.

**Section 3.11. Action Without a Meeting.** Any action required or permitted to be taken at any meeting of the Board may be taken without a meeting if a consent in writing setting forth such actions so taken is signed by all Directors and such written consent is filed with the minutes of the proceedings of the Board. Such written consent shall be sufficient if effected by fax transmission,



**Section 3.12. Quorum.** At all meetings of the Board a majority of the Directors shall constitute a quorum for the transaction of business and the votes of the majority of the Directors present at a meeting at which a quorum is present shall be the decision of the Board.

**Section 3.13. Non-Liability of Directors.** The Directors, including the members of the Initial Board of Directors shall not be liable to the Owners for any error or mistake of judgment exercised in carrying out their duties and responsibilities as Directors, except for their own individual willful misconduct, bad faith or gross negligence. The Association shall indemnify and hold harmless and defend each of the Directors against any and all liability to any Persons arising out of contracts made by the Board on behalf of Briar Pointe Estates Condominiums or the Association, unless any such contract shall have been made in bad faith or contrary to the provisions of the Declaration or these By-Laws. It is intended that the Directors shall have no personal liability with respect to any contract made by them on behalf of Briar Pointe Estates Condominiums or the Association and that in all matters the Board is acting for and on behalf of the Owners as their agent. The liability of any Owner arising out of any contract made by the Board or out of the aforesaid indemnity in favor of the Directors shall be limited to such percentage of the total liability or obligation thereunder as is equal to his Percentage Interest. Every contract made by the Board or out of the aforesaid indemnity in favor of the Directors shall be limited to such percentage of the total liability or obligation thereunder as is equal to his Percentage Interest. Every contract made by the Board or the Managing Agent on behalf of Briar Pointe Estates Condominiums shall provide that the Board and the Managing Agent, as the case may be, are acting as agent for the Owners and shall have no personal liability thereunder, except in their capacity as Owners (if applicable) and then only to the extent of their Percentage Interests.

**Section 3.14. Additional Indemnity of Directors.** The Association shall indemnify, hold harmless and defend any individual, his heirs, assigns and legal representatives made a party to any action, suit or proceeding by reason of the fact that such person is or was a Director, including individual members of the Initial Board of Directors, against the reasonable expenses, including attorney's fees, actually and necessarily incurred in connection with the defense of such action, suit or proceeding, or in connection with any appeal therein, except as otherwise specifically provided herein in relation to matters as to which it shall be adjudged in such action, suit or proceeding that such Director is liable for gross negligence or misconduct. In making such findings and notwithstanding the adjudication of any action, suit or proceeding against a Director, no Director shall be considered or deemed to be guilty of or liable for negligence or misconduct in the performance of his duties where, acting in good faith, such Director relied on the books and records of the Association or statements or advice made by or prepared by the Managing Agent or any officer or employee thereof, or any accountant, attorney or other person employed by the Association to render advice or service unless such director had actual knowledge of the falsity or incorrectness thereof; nor shall a Director be deemed guilty or liable for negligence or misconduct by virtue of the fact that he or she failed or neglected to attend a meeting or meetings of the Board.

#### **ARTICLE IV Officers**

**Section 4.01. Officers of the Association.** The principal officers of the Association shall be the President, Vice President, Secretary and Treasurer, all of whom shall be elected by the Board at the organizational meeting after the Applicable Date and at subsequent organization meetings. The Directors may appoint an Assistant Treasurer and an Assistant Secretary and such other officers as in their judgment may be necessary. Any two (2) or more offices may be held by the same person, except that the duties of the President and Secretary shall not be performed by the same person.

**Section 4.02. Election of Officers.** After the Applicable Date, the officers of the Association shall be elected annually by the Board at its duly called annual meeting of the Board. Upon an affirmative vote of a majority of all members of the Board, any officer may be removed either with or without cause and his successor elected at any regular meeting of the Board or at any special meeting of the Board called for such purpose.

**Section 4.03. The President.** The President shall be elected from among the Directors and shall be the chief executive officer of the Association. The President shall preside at all meetings of the Association and the Board, shall have and discharge all the general powers and duties usually vested in the office of president or chief executive officer of an association or a stock corporation organized under the laws of Indiana, including but not limited to the power to appoint committees from among the Owners as he or she may deem necessary to assist in the affairs of the Association and to perform such other duties as the Board may from time to time prescribe.

**Section 4.04. The Vice President.** The Vice President shall be elected from among the Directors and shall perform all duties incumbent upon the president during the absence or disability of the President. The Vice President shall also perform such other duties as these By-Laws may prescribe or as shall, from time to time, be imposed upon him by the Board or by the President.

**Section 4.05. The Secretary.** The Secretary shall be elected from among the Directors. The Secretary shall attend all meetings of the Association and of the Board and shall keep or cause to be kept a true and complete record of the proceedings of such meetings, shall perform all other duties incident to the office of the Secretary, including without limitation, keeping the minute book for the Association wherein resolutions of the Board of Directors shall be recorded, and such other duties as from time to time may be prescribed by the Board, The Secretary shall specifically see that all notices of the Association or the Board are duly given, mailed or delivered, in accordance with the provisions of these By-Laws.

**Section 4.06. The Treasurer.** The Board shall elect a Treasurer who shall maintain a correct and complete record of accounts showing, accurately, at all times the financial condition of the Association and who shall perform such other duties incident to the office of Treasurer. The Treasurer shall be the legal custodian of all monies, notes, securities and other valuables which may from time to time come into possession of the Association. The Treasurer shall immediately deposit all funds of the Association coming into his hands in some reliable bank or other depository to be designated by the Board and shall keep such bank account or accounts in the name of the Association. The Treasurer may permit the Managing Agent to handle and account for monies and other assets of the Association to the extent appropriate as part of its duties.

**Section 4.07. Assistant Officers.** The Board may, from time to time, designate and elect from among the Members an Assistant Secretary and an Assistant Treasurer who shall have such powers and duties as the officers whom they are elected to assist shall delegate to them and such other powers and duties as these By-Laws or the Board may prescribe.

## **ARTICLE V Management**

### **Section 5.01. Maintenance, Repairs and Replacements.**

- a. **Condominium Units.** Each Owner shall, at its own expense, be responsible for the maintenance, repairs, decoration and replacement of its own Condominium Unit, except as may otherwise be provided in the Declaration or herein. Each Owner shall promptly perform all maintenance and repair within its Condominium Unit which, if neglected, might adversely affect the Property. In addition, each Owner shall furnish, and shall be responsible at his own expense for the maintenance, repairs and replacements of, his Condominium Unit and appurtenant Limited Common Areas, and all equipment serving the same except to the extent otherwise provided herein or in the Declaration.
- b. **Maintenance Exceptions.** Maintenance, repairs and replacements for which each Owner is not individually responsible are water lines, gas lines, plumbing and electric lines that service the Owner's Condominium Unit only and are located within or without exterior walls of the Condominium Unit including any lines in the area from below the floor to above the ceiling if they are within an extension of the exterior walls of the Condominium Unit. Replacement of the mechanical components of fixtures serving a single Condominium Unit such as a furnace, air conditioner, lavatory, toilet, bath, whirlpool, windows, doors and garage doors and garage door openers remain the obligation of the Owner. Such foregoing mechanical maintenance by the Association is for usual and ordinary mechanical maintenance of original construction and where such repair is the result of willful or negligent misuse by the Owner a reasonable service charge shall be added to the Owner's next payment of the regular Assessment collectable and enforceable as provided for herein. A determination by the Association that total replacement of any mechanical component is necessary shall be binding upon the Owner.
- c. **Appurtenant Maintenance.** Each Owner shall be responsible for the interior surface of the doors, screens and windows which are part of such Owner's Condominium Unit, interior grouting and/or caulking and all other accessories appurtenant to the Condominium Unit or belonging to the Owner thereof and shall be responsible to wash or clean the exterior surface of any windows or doors. In the event that the maintenance or repair of any Condominium Unit is reasonably necessary in the discretion of the Board to protect the Common Areas or Limited Common Areas, or to preserve the appearance or value of the Property, or is otherwise in the interest of the general welfare of the Owners, the Board shall have the power to undertake such maintenance or repair; but no such maintenance or repair shall be undertaken without a resolution by the Board and reasonable written notice to the Owner of the Condominium Unit proposed to be maintained. The cost of any such maintenance or repair shall be assessed against the Condominium Unit on which such

maintenance or repair is performed and, when so assessed, a statement for the amount thereof shall be rendered promptly to the then Owner of the Condominium Unit at which time the Assessment shall become due and payable and a continuing lien and obligation of said Owner in all respects as provided in Section 6.06 hereof.

- d. **Certain Limited Common Areas.** Each Owner shall, at its own expense, be responsible for the replacement of the air conditioning equipment installed to service such Owner's Condominium Unit and for the decoration and general maintenance of any, patio, deck, landscaped area or porch to which there is direct access from the interior of such Condominium Unit. Any, patio, deck, or porch shall be kept free and clean of snow, ice and any other accumulation by the Owner of such Condominium Unit who shall also make all repairs thereto caused or permitted by his negligence, misuse or neglect. Each Owner shall also be responsible for any fencing installed in around any Limited Common Areas appurtenant to the Owner's Unit; provide, however, such fencing may only be installed after the same has been approved in writing, in advance, by the Board of Directors of the Association. All other repairs or replacements in, to or with respect to such, patio, deck, landscaped area or porch shall be made by the Association, and the cost thereof shall be a Common Expense.
- e. **Common Areas and Limited Common Areas.** All maintenance, repairs and replacements to the Common Areas and Limited Common Areas (except as otherwise provided in the Declaration, a Supplemental Declaration, or these By-Laws) shall be furnished by the Association as part of the Common Expenses. The Board of Directors may adopt rules and regulations concerning maintenance, repairs, use and enjoyment of the Common Areas and Limited Common Areas.
- f. **Driveways and Parking Areas.** The driveways, sidewalks and aprons of the Property, along with any private roads within the Condominium shall be privately maintained by the Association as elements of the Common Areas.

**Section 5.02. Right of Entry.** The Board of Directors, the Managing Agent, or any other Person authorized by the Board or the Managing Agent shall have the right, at reasonable times and upon reasonable prior notice (except in cases of emergency in which event no notice shall be required), to enter into each individual Condominium Unit for the purposes of inspection of the Common Areas and Limited Common Areas appurtenant thereto and replacement, repair and maintenance of the same.

**Section 5.03. Real Estate Taxes.** Real estate taxes are to be separately taxed to each Condominium Unit as provided in the Act. In the event that for any year real estate taxes are not separately assessed and taxed to each Condominium Unit but are assessed and taxed on the Property as a whole, then each Owner shall pay its proportionate share thereof in accordance with such Owner's respective Percentage Interest. If real estate taxes are assessed on the Parcel and other portions of the Real Estate, then the tax for the Parcel shall be allocated on a proportionate value basis as shall be determined by the Board of Directors.

**Section 5.04. Utilities.** Each Owner shall pay for the utilities that are separately metered and

serving such Owner's Condominium Unit.

**Section 5.05. Limitation of Liability.** The Association shall not be liable for any failure of water supply or other services to be obtained by the Association or paid for out of the Common Expenses, or for injury or damage to person or property caused by the elements or by the Owner of any Condominium Unit, or any other Person, or resulting from electricity, water, snow or ice that may leak or flow from any portion of the Common Areas or Limited Common Areas or from any pipe, drain, conduit, appliance or equipment. The Association shall not be liable to any Owner for loss or damage, by theft or otherwise, of articles that may be stored upon any of the Common Areas or Limited Common Areas. No diminution or abatement of Assessments for Common Expenses shall be claimed or allowed for inconvenience or discomfort arising from the making of repairs or improvements to the Common Areas or Limited Common Areas, or from any action taken by the Association to comply with any law, ordinance, order or directive of any municipal or other governmental authority.

**Section 5.06. Negligence.** Each Owner shall be liable for the expenses of any maintenance, repair or replacement rendered necessary by his negligence or by that of such Owner's guests, employees, agents or lessees, to the extent that such expense is not covered by the proceeds of insurance carried by the Association. An Owner shall pay the amount of any increase in insurance premiums occasioned by such Owner's use, misuse, or occupancy or abandonment of its Condominium Unit or its appurtenances or of the Common Areas or Limited Common Areas.

**Section 5.07. Costs and Attorneys' Fees.** In any proceeding arising because of failure of an Owner to make any payments required by, or to comply with any provisions of the Declaration, the Act, these By-Laws, or the rules and regulations adopted pursuant thereto, as each may be amended from time to time, the Association shall be entitled to recover its reasonable attorneys' fees incurred in connection with such default or failure.

## **ARTICLE VI**

### **Assessments**

**Section 6.01. Proposed Annual Budget.** After the Applicable Date, annually, on or before the date of the annual meeting of the Association, the Board shall cause to be prepared a proposed annual budget for the current fiscal year estimating the total amount of the Common Expenses for the current fiscal year and shall furnish a copy of such proposed budget to each Owner at or prior to the time the notice of such annual meeting is mailed or delivered to such Owners. The annual budget shall be submitted to the Owners at the annual meeting of the Association for adoption and, if so adopted, shall be the basis for the Regular Assessments for the current fiscal year. At the annual meeting of the Owners, the budget may be approved in whole or in part or may be amended in whole or in part by a Majority Vote; provided, however, that in no event shall the annual meeting of the Owners be adjourned until an annual budget is approved and adopted at such meeting, either the proposed annual budget or the proposed annual budget as amended. The annual budget and the Regular Assessments shall include the amounts required for funding the reserve account required by Section 6.04 of these By-laws. The failure or delay of the Board to prepare a proposed annual budget and to furnish a copy thereof to the Owners shall not constitute a waiver or release in any manner of the obligations of the Owners to pay the Common Expenses as herein provided,

whenever determined. Whenever, whether before or after the annual meeting of the Association, there is no annual budget approved by the Owners as herein provided for such current fiscal year, the Owners shall continue to pay Regular Assessments based upon the last approved budget or, at the option of the Board, based upon an amount no greater than one hundred and ten percent (110%) of such last approved budget, as a temporary budget.

The annual budget will include, without limitation, the following line items:

- (a) Maintenance reserves as required by Indiana Statute;
- (b) Insurance coverage to be carried by the Condominium Association as required by the Declaration and/or these Bylaws;
- (c) Management fees, to the extent a management company is retained;
- (d) Legal fees;
- (e) Accounting fees;
- (f) Common area maintenance and repairs including private street/road maintenance;
- (g) Mowing of common areas;
- (h) Snow removal;
- (i) Trash disposal;
- (j) Utilities (gas and electric); and
- (k) Irrigation.

**Section 6.02. Regular Assessments.** The annual budget as adopted by the Owners shall, based on the estimated cash required for the Common Expenses in the current fiscal year and required reserve amounts as set forth in said budget, contain a proposed assessment against each Condominium Unit based on the Percentage Interest of each Condominium Unit. Immediately following the adoption of the annual budget, each Owner shall be given written notice of such assessment against his respective Condominium Unit. In the event the Regular Assessment for a particular fiscal year is initially based upon a temporary budget, such Regular Assessment shall be revised, within fifteen (15) days following adoption of the final annual budget by the Owners to reflect the Assessment against each Condominium Unit based upon such annual budget as finally adopted by the Owners. The aggregate amount of the Regular Assessments shall be equal to the total amount of expenses provided and included in the final annual budget, including reserve funds as herein above provided. The Regular Assessment against each Condominium Unit shall be paid in advance in equal monthly installments, commencing on the first day of each calendar month. Payment of the monthly installments of the Regular Assessment shall be made to the Board of Directors or the Managing Agent, as directed by the Board of Directors; provided, however, Owners may elect to pay monthly assessments semi-annually or annually, in advance.

- a. If the Regular Assessment based upon the final annual budget adopted by the Owners exceeds the amount of the Regular Assessment based upon the temporary budget, that portion of such excess applicable to the period from the first day of the current fiscal year to the date of the next payment of the Regular Assessment that is due shall be paid with such next payment and such next payment, and all payments thereafter during such fiscal year shall be increased so that the Regular Assessment as finally determined shall be paid in full by the remaining payments due in such fiscal Year.

- b. If the Regular Assessment based upon the temporary budget exceeds the Regular Assessment based upon the final budget adopted by the Owners, such excess shall be credited against the next payment or payments of the Regular Assessment coming due until the entire amount of such excess has been so credited; provided, however, that if an Owner had paid his Regular Assessment either semi-annually or annually in advance, then the foregoing adjustments shall be made by a cash payment by or refund to, the Owner on the first day of the second month following the determination of the Regular Assessment based upon the annual budget finally adopted by the Owners.
- c. The Regular Assessments shall be payable in advance and shall commence on the first day of the calendar month following closing and delivery of deed.

The Regular Assessment for the current fiscal year of the Association shall become a lien on each separate Condominium Unit as of the first day of each fiscal year of the Association, even though the final determination of the amount of such Regular Assessment may not have been made by that date. The fact that an Owner has paid his Regular Assessment for the current fiscal year in whole or in part based upon a temporary budget and thereafter, before the annual budget and Regular Assessment are finally determined, approved and adjusted as herein provided, and sells, conveys or transfers his Condominium Unit or any interest therein, shall not relieve or release such Owner or his successor as Owner of such Condominium Unit from payment of the Regular Assessment for such Condominium Unit as finally determined, and such Owner and his successor as Owner of such Condominium Unit shall be jointly and severally liable for the Regular Assessment as finally determined. Any statement of unpaid assessments furnished by the Association prior to the final determination and adoption of the annual budget and Regular Assessment for the year in which such statement is made shall state that the matters set forth therein are subject to adjustment upon determination and adoption of the final budget and Regular Assessment for such year, and all parties to whom any such statement may be delivered or who may rely thereon shall be bound by such final determinations. Monthly (if so determined by the Board) installments of Regular Assessments shall be due and payable automatically on their respective due dates without any notice from the Board or the Association, and neither the Board nor the Association shall be responsible therefore to Owners for the same.

**Section 6.03. Special Assessments.** From time to time, Common Expenses of an unusual or extraordinary nature or not otherwise anticipated may arise. At such time and without the approval of the Owners, unless otherwise provided in these By-Laws, the Declaration or the Act, the Board of Directors shall have the full right, power and authority to make special assessments which, upon resolution of the Board, shall become a lien on each Condominium Unit, prorated in accordance with the Percentage Interest on each Condominium Unit. Without limiting the generality of the foregoing provisions, Special Assessments may be made by the Board of Directors from time to time to pay for capital expenditures or to pay for the cost of any repair or reconstruction of damage caused by fire or other cause or disaster to the extent insurance proceeds are insufficient, therefore, under the circumstances described herein or in the Declaration. Special Assessments shall become a lien on each separate Unit as of the due date of said Special Assessment, except for Units owned by the Declarant.

**Section 6.04. Reserve for Replacements.** After the Applicable Date, or such earlier time as the Declarant shall determine, the Board of Directors shall cause to be established and maintained a reserve fund for replacements by the allocation and payment to such reserve fund not less often than annually of an amount determined by the Board to be sufficient to meet the costs of periodic maintenance, repair, renewal and replacement of the Common Areas and Limited Common Areas, including, but not limited to, painting the exterior of buildings, repairing or replacing the recreational facilities, and resurfacing, repairing or replacing driveways, parking areas, sidewalks, roofs, landscaped areas and other facilities and appurtenances. In determining the amount, the Board shall take into consideration the expected useful life of such Common Areas and Limited Common Areas, projected increases in the cost of materials and labor, interest to be earned by such funds, and the advice of Declarant, the Managing Agent and consultants the Board may employ. Such fund shall be conclusively deemed to be a Common Expense. Such fund shall be deposited in an interest-bearing account with a bank or savings and loan association authorized to conduct business in Vanderburgh County, Indiana and invested in the same manner and same types of investments in which funds of a political subdivision may be invested under I.C. 5-13-9 *et. seq.* The reserve for replacements may be expended only for the purpose of effecting the periodic maintenance, repair, renewal or replacement of the Common Areas and Facilities and Limited Common Areas and equipment of the Property. It shall not be used for usual and ordinary repair expenses of the Common Areas and Facilities. The Board shall annually review the adequacy of the reserve fund. The proportionate interest of any Owner in any reserve for replacements shall be considered an appurtenance of his Condominium Unit and shall not be separately withdrawn, assigned or transferred or otherwise separated from the Condominium Unit to which it appertains and shall be deemed to be transferred with such Condominium Unit.

**Section 6.05 General Operating Reserve Fund.** The Board of Directors may establish and maintain a reserve fund for general operating expenses of a non-recurring nature by the allocation and payment to such reserve fund not less frequently than annually of such amount as the Board in its discretion determines to be reasonable under the circumstances. Such fund shall be conclusively deemed to be a Common Expense. Such fund shall be deposited in an interest bearing account with a bank or savings and loan association authorized to conduct business in Vanderburgh County, Indiana. The general operating reserve may be expended only for operating contingencies of a non-recurring nature. The proportionate interest of any Owner in any reserve fund for general operating expenses shall be considered an appurtenance of his Condominium Unit and shall not be separately withdrawn, assigned or transferred or otherwise separated from the Condominium Unit to which it appertains and shall be deemed to be transferred with such Condominium Unit.

Each Unit Owner shall pay to the Association at the closing of the purchase of the Owner's Unit a sum equal to two (2) months of the initial estimated Common Expenses Assessment as that Unit's initial contribution to the General Operating Reserve Fund. Such payments shall be in addition to the regular monthly assessment obligation and do not constitute the prepayment of regular monthly assessments. Such sums shall be deposited in the General Operating Reserve Fund.

**Section 6.06. Failure of Owner to Pay Assessments.** No Owner may exempt himself from paying Assessments, or from contributing toward the expenses of administration and of maintenance and repair of the Common Areas and, in the proper case, of the Limited Common



Areas, and toward any other expenses lawfully agreed upon, by waiver of the use or enjoyment of the Common Areas or by abandonment of the Condominium Unit belonging to such Owner. Each Owner shall be personally liable for the payment of his Percentage Interest of all Assessments. Where the Owner constitutes more than one person, the liability of such person shall be joint and several. If any Owner shall fail, refuse or neglect to make any payment of any Assessment when due, a lien for such Assessment on the Owner's Condominium Unit may be filed and foreclosed by the Board for and on behalf of the Association as provided by law; provided, however, any lien for delinquent Assessments or other charges that the Association has on a Condominium Unit will be subordinate to a first mortgage on the Condominium Unit if the mortgage was recorded before the delinquent Assessment was recorded. Upon the failure of an Owner to make timely payments of any Assessment when due, the Board may, in its discretion, assess late fees in a reasonable amount to be determined by the Board from time to time and/or accelerate the entire balance of the unpaid Assessments for the remainder of the current fiscal year and declare the same immediately due and payable, notwithstanding any other provisions hereof to the contrary. The Board may, at its option, bring a suit to recover a money judgment for any unpaid Assessment without foreclosing or waiving the lien securing the same. In any action to recover an Assessment, whether by foreclosure or otherwise, the Board, for and on behalf of the Association, shall be entitled to recover costs and expenses of such action incurred, including but not limited to reasonable attorneys' fees, from the Owner of the respective Condominium Unit.

**Section 6.07. Waiver of Lien Upon Foreclosure.** Notwithstanding anything to the contrary in the Declaration and these By-Laws, any sale or transfer of a Condominium Unit to a Mortgagee pursuant to a foreclosure of its mortgage or conveyance in lieu thereof, or a conveyance to any Person at a public sale in the manner provided by law with respect to mortgage foreclosures, shall extinguish the lien of any unpaid installment of any Assessment as to such installments that became due prior to such sale, transfer or conveyance, but extinguishment of such lien shall not relieve the prior Owner from personal liability therefor. No such sale, transfer or conveyance shall relieve the Condominium Unit or the purchaser at such foreclosure sale, or grantee in the event of conveyance in lieu thereof, from liability for any installments of Assessments thereafter becoming due or from the lien therefor. Such unpaid share of any Assessments, the lien for which has been divested as aforesaid, shall be deemed to be a Common Expense, collectible from all Owners (including the party acquiring the Condominium Unit from which it arose), as provided in the Act.

**Section 6.08. Initial Budgets and Assessments.** Notwithstanding anything to the contrary contained herein, in the Declaration, in the Act, or otherwise, until the Applicable Date, the annual budget and all Assessments shall be established by the Initial Board without meetings of or concurrence of the Owners and without the election of officers. The Initial Board of Directors may but shall not be required to create or maintain a Reserve for Replacements prior to the Applicable Date. The rights granted to the Declarant pursuant to Section 3.02 hereof shall be deemed to cover and include each Owner's right to vote on and approve the annual budget and any Assessments until the Applicable Date.

**ARTICLE VII  
Insurance**

**Section 7.01. Insurance Obtained by Association.**

a. The Association shall obtain fire and extended coverage insurance insuring the Property in an amount equal to the full replacement value thereof.

b. The Association also shall obtain comprehensive public liability insurance together with Workmen's Compensation Insurance, if applicable, employers liability insurance, if applicable, and such other liability insurance, with such coverage and limits, as the Board of Directors deems appropriate; provided, however, that public liability insurance shall have liability limits as determined by the Board of Directors from time to time for personal injury and for property damage. Such insurance shall inure to the benefit of each individual Owner, the Association, the Board of Directors, and any Managing Agent or company acting on behalf of the Association. The individual Owners, as well as any lessees of any Owners, shall have the right to recover losses insured for their benefit.

**Section 7.02. Insurance Obtained by Owners.** Each Owner shall have the right to purchase any additional insurance as he may deem necessary and each Owner shall be solely responsible for loss of or damage to the contents of his own Unit, however caused, including all floor and wall coverings, appliances, fixtures, and betterments installed by the Owner, and for loss of or damage to any of his personal property, whether or not stored or kept in his own Unit. Each Owner shall be solely responsible for obtaining his own insurance to cover any such loss or risk.

**ARTICLE VIII  
Fiscal Management**

**Section 8.01. Fiscal Year.** The fiscal year of the Association shall be fixed by the resolution of the Board of Directors or, in the absence of such resolution, shall be the calendar year.

**Section 8.02. Books of Account.** Books of account of the Association shall be kept under the direction of the Treasurer, and shall include a current, accurate and detailed record in chronological order of receipts and expenditures affecting the Property, specifying and itemizing the Common Expenses.

**Section 8.03. Inspection.** All books, records and accounts, and all vouchers accrediting the entries made thereupon, shall be available for examination by an Owner or a Mortgagee or any duly authorized agent or attorney of an Owner or Mortgagee at any time during normal business hours for purposes reasonably related to his interest as an Owner.

**Section 8.04. Annual Financial Statement.** Prior to the annual meeting of the Association, the Board of Directors shall cause to be prepared and delivered to the Owners an annual financial statement showing all income and all disbursements of the Association during the fiscal year.

**Section 8.05. Execution of Association Documents.** With the prior authorization of the Board

of Directors, all notes and contracts shall be executed on behalf of the Association by either the President or Vice President, and all checks shall be executed on behalf of the Association by such officers, agents, or other individuals as are from time to time so authorized by the Board, provided however that all checks from the Association's reserve account or working capital fund shall require the signature of two Board Members.

#### **ARTICLE IX Amendment to By-Laws**

These By-laws may be amended by a vote of not less than a Majority Vote of the Owners at a duly constituted meeting called for such purpose or in any regular meeting of the Owners.

Unless prohibited by the Act or any other applicable law, these By-laws may be amended by a majority vote of the Board of Directors.

Notwithstanding anything to the contrary contained herein or in the Declaration there shall be no amendment of the Declaration or these By-Laws prior to the Applicable Date without the consent and approval of Declarant.

#### **ARTICLE X Notices and Mortgagees**

**Section 10.01. Notice to Association.** Any Owner who places a first mortgage lien upon his Unit or the Mortgagee thereof shall notify the Secretary of the Association and provide the name and address of the Mortgagee. A record of such Mortgagee's name and address shall be kept by the Secretary of the Association and any notice required to be given to the Mortgagee pursuant to the terms of the Declaration or these By-Laws shall be deemed effectively given if mailed to such Mortgagee at the address shown in such record in the time provided. Unless notification of any such mortgages and the name and address of the Mortgagee are furnished to the Secretary, either by Owner or by the Mortgagee, no notice to any Mortgagee as may be otherwise required by the Declaration or these By-Laws shall be required, and no Mortgagee shall be entitled to vote on any matter on which he otherwise may be entitled to vote by virtue of the Declaration or By-Laws or proxy granted to such Mortgagee in connection with the mortgage.

**Section 10.02. Notice of Assessments.** Upon ten (10) days written notice to the Association and the payment of a reasonable fee, the Association shall deliver to any Owner, Mortgagee, prospective Mortgagee, title insurance company, purchaser or other prospective transferee of a Unit, a written statement setting forth the amount of all unpaid assessments, if any, with respect to the subject Unit, together with the amount of the current assessments for Common Expenses and the date(s) such assessments become due and payable. Any such written statement shall be binding upon the Association in favor of any person relying thereon in good faith.

**Section 10.03. Notices to Mortgagees.** The Association shall promptly provide to any Mortgagee of whom the Association has been provided notice under Section 10.01 of these By-laws of any of the following:

- (a) Any condemnation or casualty loss that affects either a material portion of the Condominium or the Unit securing its mortgage;
- (b) Any delinquency in the payment of Regular or Special Assessments owed by the Owner of any Unit on which said holder, insurer, or guarantor holds a mortgage, if said delinquency continues for more than sixty (60) days; and
- (c) Any lapse, cancellation or material modification of any insurance policy or fidelity bond maintained by the Association.

**ARTICLE XI**  
**Miscellaneous**

**Section 11.01. Membership.** Each Member shall automatically become a member of the Association upon delivery of title to a Condominium Unit. Such membership shall be non-transferable, and membership shall automatically transfer to the new owner upon sale or conveyance.

**Section 11.02. Notices to the Board of Directors.** Notices required to be given to the Board of Directors or to the Association may be delivered to any member of the Board of Directors or any officer of the Association either personally or by mail addressed to such Board member or officer at his Unit.

**Section 11.03. Non-waiver of Covenants.** No covenants, restrictions, conditions, obligations or provisions contained in the Declaration or these By-laws shall be deemed to have been abrogated or waived by reason of any failure to enforce the same, irrespective of the number of violations or breaches which may occur.

**Section 11.04. Agreements Binding.** All Agreements and determinations lawfully made by the Association in accordance with the procedures established in the Declaration and/or these By-laws shall be deemed to be binding on all Unit Owners, their successors and assigns.

**Section 11.05. Severability.** The invalidity of any covenant, restriction, condition, limitation, or any other provisions of these By-laws, or any part of the same, shall not impair or affect in any manner the validity, enforceability, or affect the rest of these By-laws or the Declaration.

**CERTIFICATION**

The undersigned, being first duly sworn, hereby certifies that the within and foregoing Code of By-laws of Briar Pointe Condominium Association, Inc. are true and correct.

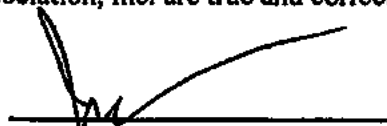
  
\_\_\_\_\_  
John J. Elpers, Incorporator

STATE OF INDIANA )  
 ) SS:  
COUNTY OF Vanderburgh )

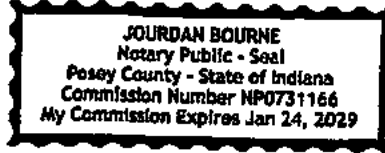

I, the undersigned, a Notary Public, in and for said County and State aforesaid, hereby certify that the said John J. Elpers, personally known to me to be the same person whose name is subscribed to the foregoing instrument, appeared before me this day in person and acknowledged that he signed, sealed and delivered such instrument as his free and voluntary act and deed for the uses and purposes therein set forth.

WITNESS my hand and Notarial Seal this 15<sup>th</sup> day of MAY, 2024.

Jourdan Bourne  
Notary Public

Jourdan Bourne  
Printed Signature

My Commission Expires:  
Jan. 24, 2029

My County of Residence:  
Posey

This instrument prepared by: Scott S. Stone, Esq., Stone & Stratman, LLP 915 Main Street, Suite 404, P. O. Box 1135, Evansville, Indiana 47706-1135, Telephone: (812) 425-5345

I affirm, under the penalties for perjury, that I have taken reasonable care to redact each Social Security number in this document, unless required by law. /s/ Scott S. Stone

**EXHIBIT "E"**

**PERCENTAGE INTEREST  
IN COMMON AREAS AND LIMITED COMMON AREAS  
OF  
BRIAR POINTE ESTATES CONDOMINIUMS**

<b>Unit</b>	<b>Address</b>	<b>Percentage Interest</b>
2003	2003 Briar Meadows Drive	6.858%
2011-1	2011 Briar Meadows Drive, Suite 1	5.469%
2011-2	2011 Briar Meadows Drive, Suite 2	6.858%
2025-1	2025 Briar Meadows Drive, Suite 1	5.469%
2025-2	2025 Briar Meadows Drive, Suite 2	6.858%
2037-1	2037 Briar Meadows Drive, Suite 1	5.469%
2037-2	2037 Briar Meadows Drive, Suite 2	6.858%
2044-1	2044 Briar Meadows Drive, Suite 1	5.469%
2044-2	2044 Briar Meadows Drive, Suite 2	6.858%
2049-1	2049 Briar Meadows Drive, Suite 1	6.858%
2049-2	2049 Briar Meadows Drive, Suite 2	5.469%
2704-1	2704 Midora Drive, Suite 1	6.858%
2704-2	2704 Midora Drive, Suite 2	5.469%
2726-1	2726 Midora Drive, Suite 1	6.858%
2726-2	2726 Midora Drive, Suite 2	5.469%
2727	2727 Midora Drive	<u>6.858%</u>
	<b>Total</b>	<b>100.00000 %</b>

**Briar Pointe Estates Condominium**

**Verified Statement of Licensed Professional Engineer**

The undersigned, Glen Meritt, Jr., an Indiana registered engineer, licensed by the State of Indiana, hereby certifies that the attached set of plans describing the buildings and condominium units of Briar Pointe Estates Condominium is an accurate copy of portions of the plans of the building as filed with and approved by the municipal or other governmental subdivisions having jurisdiction over the issuance of permits for the construction of buildings.

Respectfully submitted,

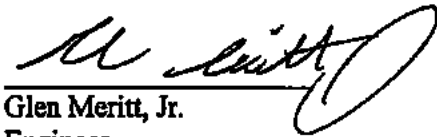

Glen Meritt, Jr.  
Engineer

Indiana License No. PE 10403870



Faint, illegible text, possibly a header or title area.



27  
25.00

John Evers Homes  
21 Mt. Ashby Rd  
Evanston IL 4774